

Wafer Style Silent Check



WCSERIES

Wafer Style Silent Check

Service Application

Municipal Water Systems

u

Industrial Class HVAC-Liquid Service

u

Industrial Piping Systems

u

Irrigation Systems

Pressure/Temperature Rating

Maximum Temperature Rating: 150°F (65°C)

u

Pressure Class: ANSI B16.1 B.S. 4504 DIN PN 10 PN 16 & PN 25

Sizes

Available in sizes 2" to 10"

NOTE: Crispin Wafer Style Check Valves are intended for liquid service only. Please consult factory when applications other than liquid are required.

Wafer Style Silent Check Valves are designed to close before the pump stops completely. This prevents flow reversal, which eliminates water hammer and the surges associated with check valve closure. Fully automatic, spring-loaded and double-guided, the valve opens as the pump starts, and closes just prior to flow reversal upon pump outage. With a standard cast iron body, bronze seat, disc and bushing, and a stainless steel spring, all internal parts of the Wafer Style Check Valve are field replaceable for ease of maintenance. Resilient seats are highly recommended for potable water or drip tight applications.

Standard and Optional Materials

NAME	MATERIAL (STANDARD)	MATERIAL (OPTIONAL)
BODY	CAST IRON ASTM A126 CLASS B	DUCTILE IRON ASTM A536 GR65-45-12
DISC	BRONZE ASTM B62	STAINLESS STEEL ASTM A743, CF8M, T316
SEAT RING*	BRONZE ASTM B62	STAINLESS STEEL ASTM A743 CF8M, T316
<i>*Resilient seating of BUNA-N or VITON available.</i>		
SPRING	S/S ASTM A313	S/S ASTM T316
BUSHING	BRONZE ASTM B584	S/SASTMA276, T316
SCREWS	STAINLESS STEEL 18-8	STAINLESS STEEL T316

Consult factory for optional construction materials.

Pressure Testing

	CLASS 125	CLASS 250
	2" (50mm) - 10" (250mm)	
NON SHOCK GAGE PRESSURE	200 psi (13.6 BAR)	400 psi (27.2 BAR)
SHELL TEST PRESSURE	300 psi (20.4 BAR)	750 psi (51.0 BAR)
SEAT TEST PRESSURE	300 psi (20.4 BAR)	400 psi (27.2 BAR)



Please consult the factory for information on ordering Wafer Style Check Valves with higher pressure classes than those listed above.



Wafer Style Silent Check

Wafer Style Silent Check

WC SERIES

MODEL		Valve Dimensions							BOLTS SIZE in. (mm)			
STD TRIM	STD TRIM RESILIENT	S/S TRIM	S/S TRIM RESILIENT	ANSI CLASS	VALVE SIZE	FACE TO FACE (B) in. (mm)	MAX. DIA. in. (mm)	W T. lb. (kg.)	NO.		125	250
									12	25		
WC20	WC20.R	WC20.2	WC20.2R	125,250	2 (50)	2 5/8 (66.7)	4 1/4 (108)	5 (2.5)	4	8	5/8 (16)x5 (127)	5/8 (16)x5 1/2 (134)
WC250	WC250.R	WC250.2	WC250.2R	125,250	2 1/2 (65)	2 7/8 (73)	5 (127)	7 (3)	4	8	5/8 (16)x5 (127)	3/4 (16)x6 (152)
WC30	WC30.R	WC30.2	WC30.2R	125,250	3 (80)	3 1/8 (80)	5 3/4 (146)	11 (5)	4	8	5/8 (16)x6 (152)	3/4 (16)x7 (178)
WC40	WC40.R	WC40.2	WC40.2R	125,250	4 (100)	4 (101.6)	7 (178)	18 (8)	8	8	5/8 (16)x7 (178)	3/4 (20)x8 (203)
WC50	WC50.R	WC50.2	WC50.2R	125,250	5 (125)	4 5/8 (117.5)	8 3/8 (213)	25 (12)	8	8	3/4 (16)x8 (203)	3/4 (16)x9 (229)
WC60	WC60.R	WC60.2	WC60.2R	125,250	6 (150)	5 1/2 (139.7)	9 3/4 (248)	36 (16)	8	12	3/4 (20)x9 (229)	3/4 (24)x10 (254)
WC801	WC801.R	WC801.2	WC801.2R	125	8 (200)	6 1/2 (165.1)	13 3/8 (340)	83 (28)	8	—	3/4 (20)x10 (254)	—
WC802	WC802.R	WC802.2	WC802.2R	250	8 (200)	6 1/2 (165.1)	13 3/8 (340)	86 (39)	—	12	—	7/8 (24)x12 (305)
WC1001	WC1001.R	WC1001.2	WC1001.2R	125	10 (250)	8 1/4 (209.6)	16 (406)	132 (60)	12	—	7/8 (24)x12 (305)	—
WC1002	WC1002.R	WC1002.2	WC1002.2R	250	10 (250)	8 1/4 (209.6)	16 (406)	138 (63)	—	16	—	1 (27)x14 (356)

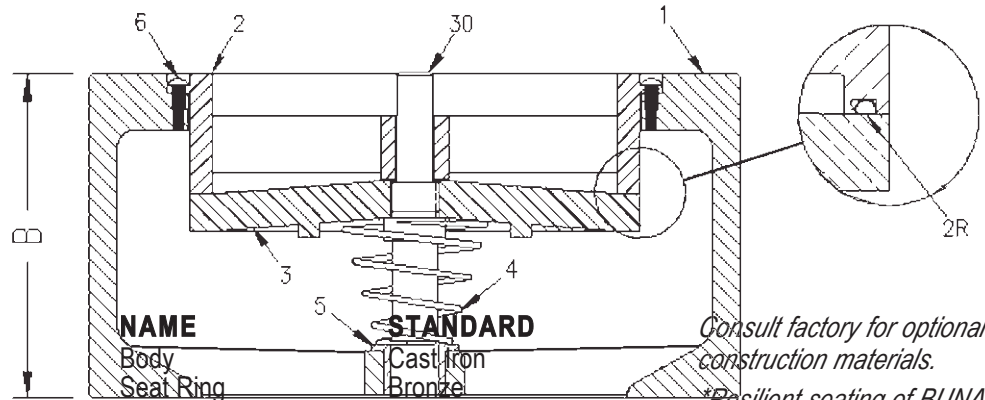

PART #	NAME	STANDARD	
1	Body	Cast Iron	Consult factory for optional construction materials.
2*	Seat Ring	Bronze	*Resilient seating of BUNA-N or VITON available.
3	Disc	Bronze	Materials and Prices Subject to Change Without Notice.
4	Spring	Stainless Steel	
5	Bushing	Bronze	
6	Screws	Stainless Steel	

Valve Diagrams

* The inside diameter of the mating flange must overlap the valve seat in order to provide proper seat retention. The flange gasket must be sized to provide a seal between the internal diameter of the valve body and the outside diameter of the seat.

Wafer Style Silent Check



WCSERIES

Wafer Style Silent Check

Flow Velocity

These valves have a maximum recommended flow velocity of 10 feet per second. In addition, flow curves are based on the flow of clean water at ambient temperature.

Line Placement

Preferred piping standards recommend placing check valves 5 to 10 pipe diameters from any turbulence producing devices (i.e. pumps, elbow, etc.). This installation recommendation should be followed to prevent increased valve

Special Maintenance Note:

The Wafer Style Silent Check Valve should never be inspected by only removing the valve inlet flange piping. If this is done, seat damage to the valve or personal injury to the inspector may occur. If the valve must be serviced, it should be isolated and the line pressure relieved on both sides of the valve. For additional instructions, consult the Operation and Maintenance section of the Crispin Multiplex Manufacturing Company catalog. These valves are intended for use on municipal water systems or approved commercial and/or industrial applications only.

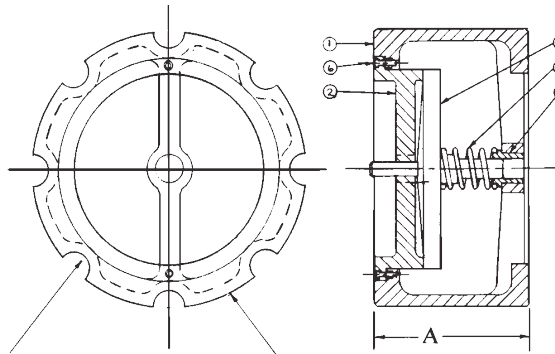

ANSI CLASS 125 lb. Bolt Location

ANSI CLASS 250 lb. Bolt Location

Head Loss Characteristics

Wafer Style Silent Check Valve Performance Curves

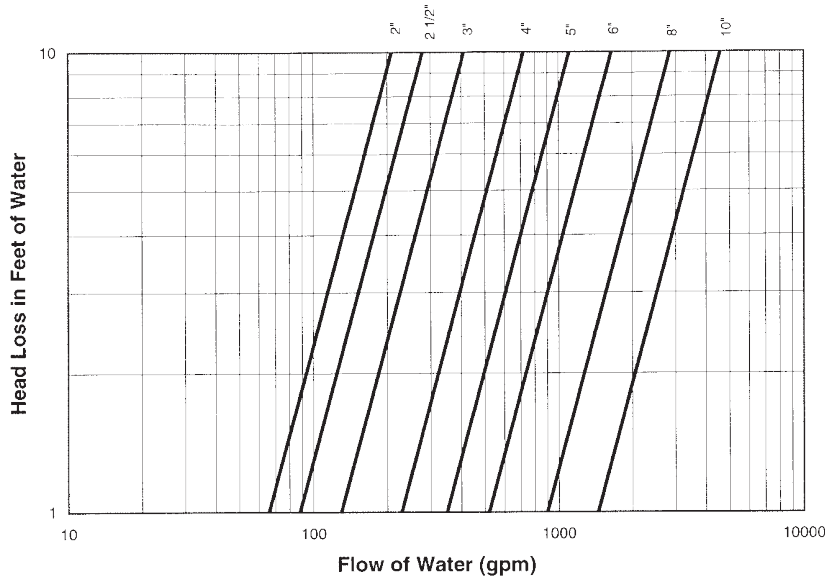



GC/WC SERIES



Wafer Style Silent Check

Technical Reference

Testing

Each Crispin Check Valve receives a shell and seat hydrostatic test relative to the valve design operating pressure and materials of construction.

Painting

After testing, each valve is externally painted with a phenolic primer.

Caution

These valves are not recommended for raw sewage service.

Damage to the valve may result, if used with specialty flanges or connectors having full or partial rubber facing.

Consult the factory for recommendation of valves used in air, steam, hot water or boiler feed systems.

Construction Features

- BODY** The body is available in most castable metals.
- SEATS & DISCS** Seats are flat. Cast iron or bronze have bronze seats and discs. Carbon steel or stainless steel bodies have stainless steel seats and discs.
- RESILIENT SEATS** The seat can be made to accommodate a resilient surface of BUNA-N or VITON™. This resilient seat mates with the flat metallic surface of the disc.
- SPRINGS** Helical constant pitch or conical springs are used in the Globe or Wafer Style Valves. The valves are designed to crack open at .25psi to .5psi.
- BUSHING** Bushings are bronze when a cast iron or bronze body is required, and stainless steel is used when a carbon steel or stainless steel body is required.

Installation Instructions

- 1 Valves may be installed vertically, horizontally, or at other angles.
- 2 Install the valve with proper positioning of the flow arrow. Support and align adjacent piping and the valve. Install lubricated flange bolts, hand tighten, then torque the bolts using the cross-over flange bolt tightening method to load the bolts evenly and eliminate concentrated stresses.
- 3 Valve must be mounted to ANSI cast iron or steel flanges with conventional flat face or ring gaskets. The Mating Flange I.D. must overlap the valve seat. Proper centering of ring gaskets is important to prevent internal leakage.
- 4 Never lift the valve by the bronze or stainless steel trim.

Additional Check Valves Available From Crispin: Tilting Disc, Rubber Flapper and Swing Check Valves

Submittal Sheet for Crispin WC Series

2 1/2"–5" Wafer Check Valve

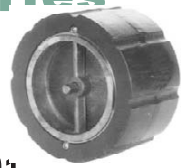

Date: October, 2001

Specifications

The Silent Wafer Check Valve(s) shall be fully automatic, spring loaded and double guided. The valve shall open as the pump starts, and close just prior to flow reversal upon pump outage.

The valve shall have a cast iron body, bronze seat, disc and bushing, and stainless steel spring. All internal parts shall be field replaceable for ease of maintenance.

The valve shall be model as manufactured by Crispin-Multiplex Manufacturing Co., Crispin Valve Division, Berwick, PA.

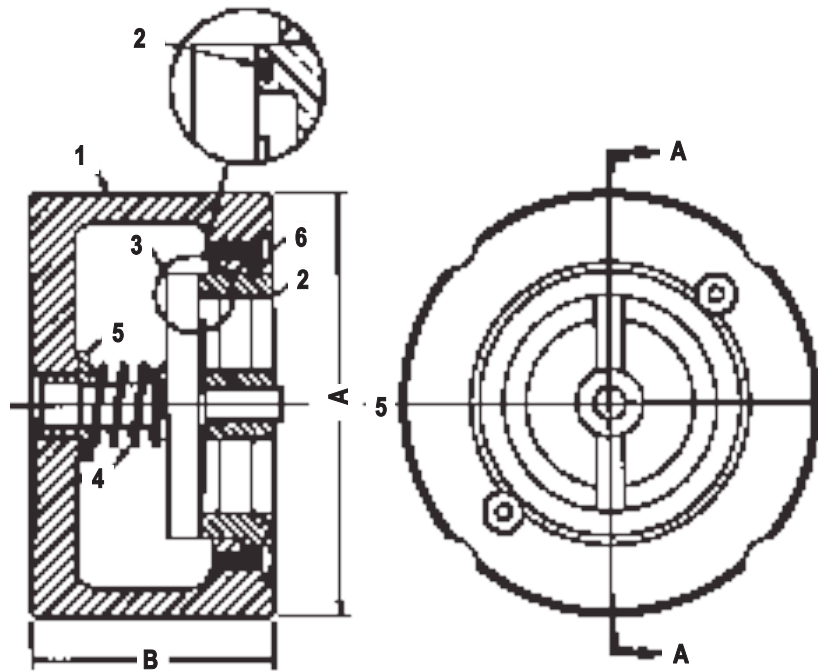

Size Specifications

MODEL	VALVE SIZE	A	B	WEIGHT
WC250	2 1/2" 125#/250# FLG	5.00	3.00	7
WC30	3" 125#/250# FLG	5.75	3.25	11
WC40	4" 125#/250# FLG	7.00	4.00	18
WC50	5" 125#/250# FLG	8.50	4.75	25

* Parts are interchangeable and optional at customer's request
For resilient seat, add .R to Model Number.

Parts List for Globe Check Valve

ITEM	DESCRIPTION	MATERIAL	ASTM
1	BODY	CAST IRON	A126 CL.B
*2	SEAT	CAST BRONZE	B62
*2R	RESILIENT SEAT	CAST BRONZE/BUNA- N RUBBER	B62/D2000
3	DISC	CAST BRONZE	B62
4	SPRING	STAINLESS STEEL	A313
5	BUSHING	BRASS	B505
6	SCREW	STAINLESS STEEL	A194

SUBMITTAL SHEET FOR WC SERIES



Submittal Sheet for Crispin WC

6"—10" Wafer Check Valve

Date: October, 2001

Size Specifications

MODEL	VALVE SIZE	A	B	WEIGHT
WC60	6" 125#/250# FLG	9.75	5.50	36
WC801	8" 125# FLG	13.50	6.50	83
WC802	8" 250# FLG	13.50	6.50	86
WC1001	10" 125# FLG	16.00	8.25	132
WC1002	10" 250# FLG	16.00	8.25	138

Parts List for Globe Check Valve

ITEM	DESCRIPTION	MATERIAL	ASTM
1	BODY	CAST IRON	A126 CL.B
*2	SEAT	CAST BRONZE	B62
*2R	RESILIENT SEAT	CAST BRONZE/BUNA- N RUBBER	B62/D2000
3	DISC	CAST BRONZE	B62
4	SPRING	STAINLESS STEEL	A313
5	BUSHING	BRASS	B62
6	SCREW	STAINLESS STEEL	A193
30	SHAFT	BRONZE	B62

Specifications

The Silent Wafer Check Valve(s) shall be fully automatic, spring loaded and double guided. The valve shall open as the pump starts, and close just prior to flow reversal upon pump outage.

The valve shall have a cast iron body, bronze seat, disc and bushing, and stainless steel spring. All internal parts shall be field replacable for east of maintenance.

The valve shall be model _____ as manufactured by Multiplex Manufacturing Co., Berwick, PA.

* Parts are interchangeable and optional at customer's request

For resilient seat, add .R to Model Number.
Also available with stainless steel trim.

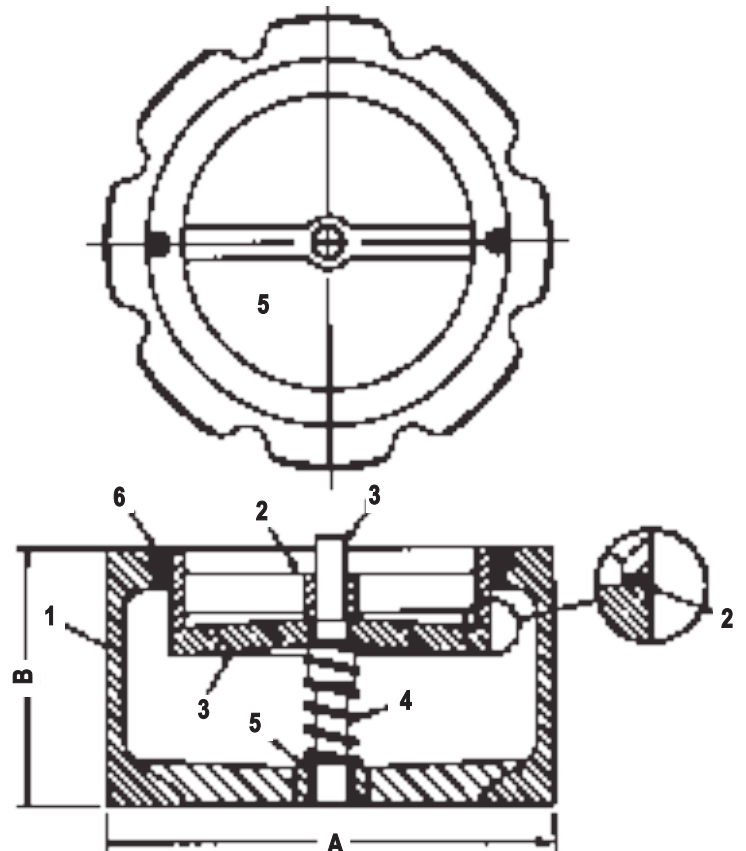

SUBMITTAL SHEET FOR WC SERIES