



Section N

10/2014

Web Revision 10/02/2015

Ford Fabricated Steel Products



Contents

| | Page |
|---|---------|
| Product Numbering System | 3 |
| Information | 4 - 7 |
| Steel Transition Coupling / 4" through 24" / Style FC23 / Style FC24 | 8 - 11 |
| Steel Coupling / 1/2" through 12" / Style FC3 | 12 & 13 |
| Steel Coupling / 14" through 60" / Style FC4 | 14 -16 |
| Steel Coupling with End Cap / 14" through 24" / Style FC4 | 17 |
| Steel Transition Coupling / 14" through 60" / Style FC5 | 18 & 19 |
| Steel Reducing Coupling / 2" through 60" / Style FC6 | 20 & 21 |
| Steel Flange Coupling Adapter / 4" through 48" / Style FCA | 22 - 25 |
| Ford Dismantling Joint / 4" through 36" / Style FDJ | 26 |
| Steel Expansion Joint / 4" through 24" / Style FEJ | 27 - 29 |
| Restrainer Assembly / 4" through 16" / Style FR | 30 & 31 |
| Steel Weld-On Tapping Sleeve / 3" through 48" / Style FWS | 32 |
| Miscellaneous Custom Steel Fittings | 33 |
| Stainless Steel Inserts for HDPE Pipe | 34 |
| Pipe O.D. Chart for 3" through 60" pipe | 35 |
| Installation Instructions for Ford Fabricated Steel Couplings | 36 |
| Warranty | 40 |

*The information in this catalog is correct at the time of publication. Item and option availability, including specifications are subject to change without notice. **Items in this catalog section are not returnable and are subject to cancellation charges.***

The Ford Meter Box Company, Inc. manufacturing facilities are at the following locations:

1. The Ford Meter Box Company, Inc. - Main Office
775 Manchester Avenue, P.O. Box 443
Wabash, Indiana 46992-0443
Phone: 260-563-3171 FAX: 800-826-3487
2. The Ford Meter Box Company, Inc. - Pipe Products Division
815 Miles Parkway
Pell City, Alabama 35125
Phone: 205-884-4480 FAX: 205-884-4484

FABRICATED STEEL PRODUCTS SECTION N

| | | |
|---|---|---|
| <p>TYPE OF COUPLING</p> <p>FC23 or FC24 = Steel Transition Coupling for 4" thru 24" *FC3 = Steel Coupling for 1/2" thru 12" FC4 = Steel Coupling for 14" thru 60" FC5 = Steel Transition Coupling for 14" thru 60" FC6 = Steel Reducing Coupling for 2" thru 60"</p> <p>Note: Custom fabrications are welcomed.</p> | <p style="text-align: center;">CENTER SLEEVE WALL THICKNESS</p> <p style="text-align: center;">A = 1/4" steel B = 3/8" steel</p> <p style="text-align: center;">(use only with FC4 & FC5)</p> | <p style="text-align: right;">COUPLING LENGTH</p> <p style="text-align: right;">05 = 5" 07 = 7" 10 = 10" 12 = 12" 15 = 15" 20 = 20" 24 = 24"</p> |
|---|---|---|

FC5-2580-2632-B 15 R

O.D. SIZE

| | |
|--|--|
| <p>FC23 or FC24 - Small end FC3 - Both Ends O.D. FC4 - Both Ends O.D. FC5 - Small End O.D. FC6 - Large End O.D.</p> | <p>FC23 or FC24 - Large end FC5 - Large End O.D. FC6 - Small End O.D.</p> |
|--|--|

COATING, BOLTS AND GASKET OPTIONS

| COATING AND BOLT COMBINATIONS | | | | | | | | |
|-------------------------------|----------------------|---------------------------|---------------------------|--------------------------|----------------------|---------------------------|---------------------------|--------------------------|
| GASKET MATERIAL | Standard Shop Coat | | | | Epoxy Coated | | | |
| | Standard Alloy Bolts | 304 Stainless Steel Bolts | 316 Stainless Steel Bolts | Electro Galvanized Bolts | Standard Alloy Bolts | 304 Stainless Steel Bolts | 316 Stainless Steel Bolts | Electro Galvanized Bolts |
| SBR Rubber | R | X | Q | G | E | Y | Z | K |
| Buna-N Rubber | N | H | J | F | C | P | T | O |
| EPDM Rubber | S | M | V | W | A | B | D | L |

Note: See item listings in catalog section to assure that desired sizes and options are available.
 *See page N-12 for more specific Numbering System of FC3 coupling.



Ford Meter Box - Pipe Products Division
 Pell City, Alabama

Information

FC23/FC24 Steel Transition Coupling

- Steel center sleeve
- Ductile iron end rings
- Rated working pressure - 4" - 18" 200 psi, 20" - 24" 150 psi
- Nominal sizes 4" through 24"
- See page N-8

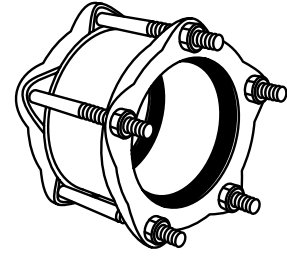

FC3 Steel Coupling

- Steel center sleeve
- Steel or ductile iron end rings
- Standard gasket specially compounded for water applications
- Nominal sizes 1/2" through 12"
- See page N-12

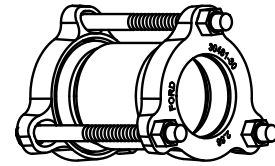

FC4 Steel Coupling

- Carbon steel center sleeve
- Carbon steel end rings
- Large variety of gasket, hardware and coating options
- Nominal sizes 14" through 60"
- See page N-14

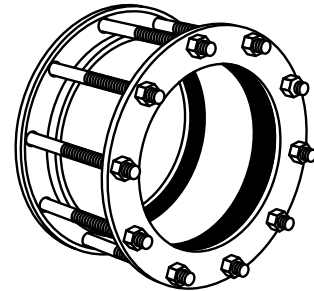

FC4 Steel End Cap Coupling

- Provides a temporary end or air relief
- Options include a tapped or blind end cap
- Construction and options similar to FC4
- See page N-17

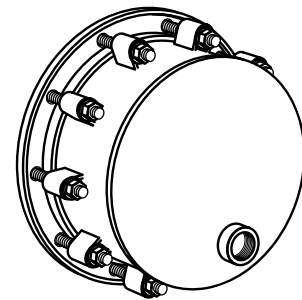

FC5 Steel Transition Coupling

- Steel center sleeve and end rings
- Maximum transition between pipes is 1" except as listed
- Nominal sizes 14" through 60"
- See page N-18

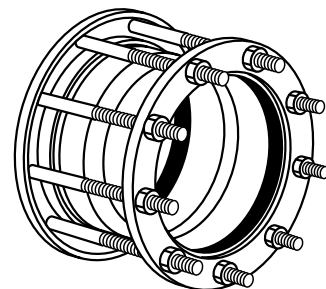

Information

FC6 Steel Reducing Coupling

- Steel center sleeve and end rings
- Connects pipes with diameter variations in excess of 1"
- 150 psi R.W.P. with reduction of two nominal sizes or less
- Nominal sizes 2" through 60"
- See page N-20

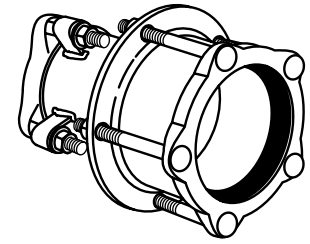

FCA Steel Flanged Coupling Adapters

- Steel flange and center sleeve
- Ductile iron or steel end rings
- Options include anchor studs and harness assemblies
- Nominal sizes 4" through 48"
- See page N-22

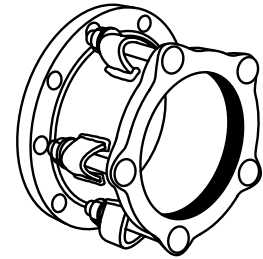

FDJ Dismantling Joint

- 4" - 12" ductile iron body and end ring (larger sizes are steel)
- Steel adjusting pipe and flange
- Nominal sizes 4" through 36" (larger available)
- See page N-26

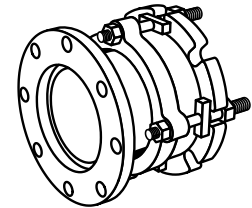

FEJ Expansion Joint

- Allows maximum of 10" pipe movement
- Nickel chrome plated slip pipe
- Nominal sizes 4" through 24"
- Supplied with plain ends for field welding or flanged ends
- See page N-27

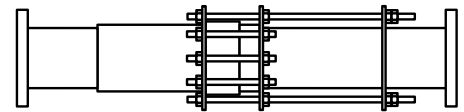

Ford Restrainer Assemblies

- FR1 - For pipe that cannot be field welded
- FR2 - Requires field welding of steel lug to steel pipe
- FR3 - Used for restraint of steel pipe
- See page N-30

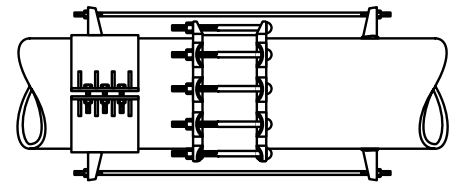

FWS Weld on Tapping Sleeve

- Specifically designed for steel pipe
- Rounded corners to facilitate a continuous weld stroke
- Nominal sizes 3" through 48"
- See page N-32

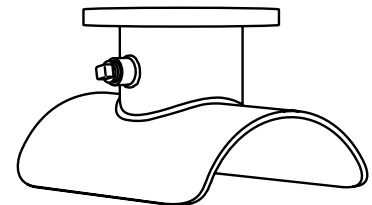

Custom Fabrications

- Manufactured to meet AWWA C208 standards
- See page N-33

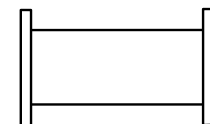

Material Specification

Submittal Drawings: The Ford Meter Box Company will supply, upon request, detailed submittal drawings of any of our pipe products including fabricated steel products identified in this catalog section. These submittal documents include cross sectional drawings of our products as well as detailed material specifications and other information specific to your particular job requirements. Please contact your Ford Meter Box Customer Service Representative for more information.

General Design Information: All of the fabricated steel products found in this catalog section are built to meet the requirements of applicable AWWA standards. Some Ford fabricated products are designed and manufactured to fit a specific pipe diameter. In order to accommodate the manufacturing tolerances of various pipeline materials, couplings without an indicated range have a built in tolerance of ± 0.10 " as measured on the diameter.

| | | |
|----------------------------------|-----------------------|---|
| Center Sleeve: | 1/2" - 60" | Carbon steel per ASTM A36 / minimum yield = 36,000 psi |
| End Rings: | 4" - 24" 14" - 60" | Ductile iron per ASTM A536 Type 65-45-12 AISI 1018-1020 cold rolled or extruded carbon steel / minimum yield = 40,000 psi |
| Hardware: (fasteners) | 1/2" - 60" | STANDARD: Corrosion resistant high strength low alloy steel per AWWA C111 and ASTM A242 OPTIONAL: Type 304 stainless steel per ASTM A193 and A194 OPTIONAL: Type 316 stainless steel per ASTM A193 and A194 OPTIONAL: Zinc plated with di-chromate seal (electro-galvanized) |
| Gaskets: | 4" - 60" | STANDARD: Molded or extruded styrene butadiene rubber (SBR) per ASTM D2000 / Maximum recommended operating temperature = 150° F OPTIONAL: Molded or extruded Buna-N per ASTM D2000 Maximum recommended operating temperature = 220° F OPTIONAL: Molded or extruded EPDM per ASTM D2000 Maximum recommended operating temperature = 300° F |
| Finish: | | STANDARD: Black shop coat (excluding FC3 Style) OPTIONAL: Fusion bonded epoxy coating / minimum thickness 10 - 12 mils |

Additional hardware, gasket and finish options are available. Please contact the Ford Customer Service Department for more information about these and other options available for fabricated steel products.

Options for Ford Fabricated Steel Products

Special Coatings and Linings

The standard coating applied to Ford Fabricated Products is a black, water-based shop coat suitable as an undercoat for many field-applied coatings. The most commonly requested and specified optional coating is epoxy. Our standard epoxy application process is a heat activated fusion bonding of epoxy powder to the fabricated steel part. The coating conforms to the requirements of AWWA C213. Other special primers and coatings are available.



Pipe Stops

Pipe stops are optional for most Section N coupling products. The stops prevent a coupling from sliding completely onto a piece of pipe. The purpose of these devices is to provide a means to center the coupling over the pipe ends during installation. The use of pipe stops limits the versatility of couplings by preventing the insertion of a pipe section, valves, or other fittings into existing pipelines. The repair of piping joined with couplings built with pipe stops can only be accomplished by cutting and removing a portion of the pipeline.

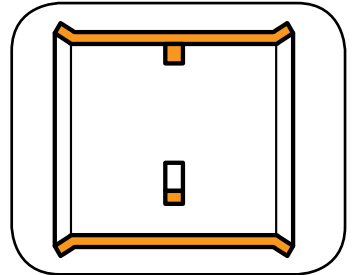

Anchor Studs

Anchor studs are a common method used to restrain axial pipe movement in couplings. Although most frequently used in applications that include flanged coupling adapters, anchor studs may be incorporated into the design of flexible couplings as well. Anchor studs may not be used with AC pipe or plastic piping material. The illustration shows an example of a typical anchor stud application. Note that the proper installation requires the stud to be assembled by threading through the coupling and into a hole that must be drilled in the pipe.

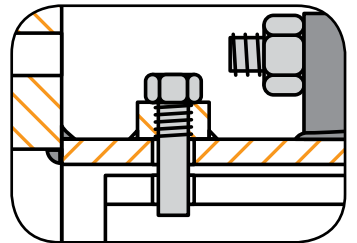

Fasteners

Standard bolts and nuts shipped with our fabricated steel products are corrosion resistant, high strength low alloy steel that conform to the requirements of AWWA C111 and ASTM A242. When a fabricated steel product will be used in an especially corrosive environment, it may be necessary to use hardware that is more corrosion resistant than standard fasteners. Ford can supply several options for this requirement including Type 304 and Type 316 stainless steel. Another option frequently specified is "Galvanized." The Ford Meter Box Company does not recommend the use of "Hot-Dipped Galvanized" fasteners because the thickness of the coating interferes with the threads of the bolt and nut. The alternative we offer is a steel bolt with electro-deposited zinc plating and a di-chromate seal, commonly referred to in our literature as "Electro-Galvanized."



FIB Ford Insulating Boot

For applications that require electrical isolation of main line piping from attached couplings, an insulating boot can be supplied with most Section N products. The boot fits over the end of one or both of two plain end pipes to be joined and electrically insulates the pipes from each other and from the attached coupling. Insulating boots add .25" to the pipe outside diameter. Please refer to Ford Catalog section M for details on FIB's through 12". Information about larger sizes can be obtained by calling the Ford Meter Box Company Customer Service Department in Wabash.

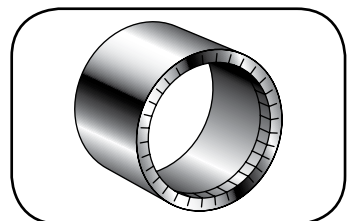

Ford Transition Couplings

Style FC23/FC24 - Fabricated Steel Center Sleeve with Ductile Iron End Rings

The extremely versatile Ford FC23 and FC24 Transition Couplings are designed to connect plain end pipes with different OD's for nominal pipe sizes ranging from 4" through 24". FC23 couplings are manufactured using center sleeves with a thickness of 1/4" while FC24 couplings utilize 3/8" thick material for the center sleeve. Each gasket is clearly identified with the pipe OD range that it will accommodate. The FC23 and FC24 couplings are available in a variety of center sleeve lengths including the popular 5, 7, and 10 inch lengths. Longer sleeves are available.

Finish - Black shop coat / color coded end rings
Optional: Fusion bonded epoxy



Center Sleeve - ASTM A36 Carbon Steel
FC23 - 1/4" thickness
FC24 - 3/8" thickness

Gaskets - SBR molded rubber
Optional: - Buna-N
- EPDM

End Rings - Ductile iron per ASTM A536

Rated Working Pressure -
4" - 18" = 200 psi
20" - 24" = 150 psi

Bolts and Nuts - Corrosion resistant high strength low alloy steel per ASTM A242 and AWWA C111
Optional: -Type 304 stainless steel
-Type 316 stainless steel
-Electro-galvanized steel
-Blue fluorocarbon coating

Caution: Flexible couplings do not restrain axial pipe movement. Unbalanced forces created by internal water pressure or external forces must be restrained.

How to order FC23/FC24 Couplings:

Locate the gasket ranges that accommodate your pipe O.D.s for both coupling ends. Select the desired center sleeve length and use the corresponding catalog number. For coupling lengths, coating and bolt options not listed in the following charts, select the proper catalog number for your pipe O.D.s for both coupling ends and substitute the desired option codes listed below.

FC23-663-720-10 R

Product Identification: Steel Transition Coupling

Use FC24 when ordering center sleeve with 3/8" thickness.

Small End
(Top range of gasket)

Large End
(Top range of gasket)

Center Sleeve Length
05 = 5"
07 = 7"
10 = 10"
12 = 12"
15 = 15"
20 = 20"
24 = 24"

| COATING, BOLTS AND GASKET OPTIONS | | | | |
|-----------------------------------|-------------------------------|---------------------------|---------------------------|--------------------------|
| GASKET MATERIAL | COATING AND BOLT COMBINATIONS | | | |
| | Standard Alloy Bolts | 304 Stainless Steel Bolts | 316 Stainless Steel Bolts | Electro Galvanized Bolts |
| Standard Shop Coat | | | | |
| SBR Rubber | R | X | Q | G |
| Buna-N Rubber | N | H | J | F |
| EPDM Rubber | S | M | V | W |
| Epoxy Coated | | | | |
| SBR Rubber | E | Y | Z | K |
| Buna-N Rubber | C | P | T | O |
| EPDM Rubber | A | B | D | L |

Note: See item listings in catalog section to assure that desired sizes and options are available

Ford Transition Couplings

Style FC23/FC24 - Fabricated Steel Center Sleeve with Ductile Iron End Rings (4" through 24")

| NOM. PIPE SIZE | 1ST END GASKET RANGE | 2ND END GASKET RANGE | LENGTH OF CENTER SLEEVE | CATALOG NUMBER | NUMBER OF BOLTS | APPROX. WT. LBS. |
|----------------|----------------------|----------------------|-------------------------|------------------|-----------------|------------------|
| 4" | 4.00 | 4.00 | 5" | FC23-400-400-05R | 3 | 17 |
| | 4.00 | 4.00 | 7" | FC23-400-400-07R | 3 | 22 |
| | 4.00 | 4.00 | 10" | FC23-400-400-10R | 3 | 28 |
| | 4.00 | 4.50 | 5" | FC23-400-450-05R | 3 | 17 |
| | 4.00 | 4.50 | 7" | FC23-400-450-07R | 3 | 22 |
| | 4.00 | 4.50 | 10" | FC23-400-450-10R | 3 | 28 |
| | 4.00 | 4.80-5.14 | 5" | FC23-400-514-05R | 3 | 17 |
| | 4.00 | 4.80-5.14 | 7" | FC23-400-514-07R | 3 | 22 |
| | 4.00 | 4.80-5.14 | 10" | FC23-400-514-10R | 3 | 28 |
| | 4.00 | 5.15-5.57 | 5" | FC23-400-557-05R | 3 | 17 |
| | 4.00 | 5.15-5.57 | 7" | FC23-400-557-07R | 3 | 22 |
| | 4.00 | 5.15-5.57 | 10" | FC23-400-557-10R | 3 | 28 |
| | 4.50 | 4.50 | 5" | FC23-450-450-05R | 3 | 17 |
| | 4.50 | 4.50 | 7" | FC23-450-450-07R | 3 | 22 |
| | 4.50 | 4.50 | 10" | FC23-450-450-10R | 3 | 28 |
| | 4.50 | 4.80-5.14 | 5" | FC23-450-514-05R | 3 | 17 |
| | 4.50 | 4.80-5.14 | 7" | FC23-450-514-07R | 3 | 22 |
| | 4.50 | 4.80-5.14 | 10" | FC23-450-514-10R | 3 | 28 |
| | 4.50 | 5.15-5.57 | 5" | FC23-450-557-05R | 3 | 17 |
| | 4.50 | 5.15-5.57 | 7" | FC23-450-557-07R | 3 | 22 |
| | 4.50 | 5.15-5.57 | 10" | FC23-450-557-10R | 3 | 28 |
| | 4.80-5.14 | 4.80-5.14 | 5" | FC23-514-514-05R | 3 | 17 |
| | 4.80-5.14 | 4.80-5.14 | 7" | FC23-514-514-07R | 3 | 22 |
| | 4.80-5.14 | 4.80-5.14 | 10" | FC23-514-514-10R | 3 | 28 |
| | 4.80-5.14 | 5.15-5.57 | 5" | FC23-514-557-05R | 3 | 17 |
| | 4.80-5.14 | 5.15-5.57 | 7" | FC23-514-557-07R | 3 | 22 |
| | 4.80-5.14 | 5.15-5.57 | 10" | FC23-514-557-10R | 3 | 28 |
| | 5.15-5.57 | 5.15-5.57 | 5" | FC23-557-557-05R | 3 | 17 |
| | 5.15-5.57 | 5.15-5.57 | 7" | FC23-557-557-07R | 3 | 22 |
| | 5.15-5.57 | 5.15-5.57 | 10" | FC23-557-557-10R | 3 | 28 |
| 6" | 6.00 | 6.00 | 5" | FC23-600-600-05R | 4 | 19 |
| | 6.00 | 6.00 | 7" | FC23-600-600-07R | 4 | 24 |
| | 6.00 | 6.00 | 10" | FC23-600-600-10R | 4 | 29 |
| | 6.00 | 6.63 | 5" | FC23-600-663-05R | 4 | 19 |
| | 6.00 | 6.63 | 7" | FC23-600-663-07R | 4 | 24 |
| | 6.00 | 6.63 | 10" | FC23-600-663-10R | 4 | 29 |
| | 6.00 | 6.90-7.20 | 5" | FC23-600-720-05R | 4 | 19 |
| | 6.00 | 6.90-7.20 | 7" | FC23-600-720-07R | 4 | 24 |
| | 6.00 | 6.90-7.20 | 10" | FC23-600-720-10R | 4 | 29 |
| | 6.00 | 7.21-7.56 | 5" | FC23-600-756-05R | 4 | 19 |
| | 6.00 | 7.21-7.56 | 7" | FC23-600-756-07R | 4 | 24 |
| | 6.00 | 7.21-7.56 | 10" | FC23-600-756-10R | 4 | 29 |
| | 6.63 | 6.63 | 5" | FC23-663-663-05R | 4 | 19 |
| | 6.63 | 6.63 | 7" | FC23-663-663-07R | 4 | 24 |
| | 6.63 | 6.63 | 10" | FC23-663-663-10R | 4 | 29 |
| | 6.63 | 6.90-7.20 | 5" | FC23-663-720-05R | 4 | 19 |
| | 6.63 | 6.90-7.20 | 7" | FC23-663-720-07R | 4 | 24 |
| | 6.63 | 6.90-7.20 | 10" | FC23-663-720-10R | 4 | 29 |
| | 6.63 | 7.21-7.56 | 5" | FC23-663-756-05R | 4 | 19 |
| | 6.63 | 7.21-7.56 | 7" | FC23-663-756-07R | 4 | 24 |
| | 6.63 | 7.21-7.56 | 10" | FC23-663-756-10R | 4 | 29 |
| | 6.90-7.20 | 6.90-7.20 | 5" | FC23-720-720-05R | 4 | 19 |
| | 6.90-7.20 | 6.90-7.20 | 7" | FC23-720-720-07R | 4 | 24 |
| | 6.90-7.20 | 6.90-7.20 | 10" | FC23-720-720-10R | 4 | 29 |
| | 6.90-7.20 | 7.21-7.56 | 5" | FC23-720-756-05R | 4 | 19 |
| | 6.90-7.20 | 7.21-7.56 | 7" | FC23-720-756-07R | 4 | 24 |
| | 6.90-7.20 | 7.21-7.56 | 10" | FC23-720-756-10R | 4 | 29 |
| | 7.21-7.56 | 7.21-7.56 | 5" | FC23-756-756-05R | 4 | 19 |
| | 7.21-7.56 | 7.21-7.56 | 7" | FC23-756-756-07R | 4 | 24 |
| | 7.21-7.56 | 7.21-7.56 | 10" | FC23-756-756-10R | 4 | 29 |

Additional sizes on following page.

Ford Transition Couplings

Style FC23/FC24 - Fabricated Steel Center Sleeve with Ductile Iron End Rings (4" through 24") *Continued . . .*

| NOM. PIPE SIZE | 1ST END GASKET RANGE | 2ND END GASKET RANGE | LENGTH OF CENTER SLEEVE | CATALOG NUMBER | NUMBER OF BOLTS | APPROX. WT. LBS. |
|----------------|----------------------|----------------------|-------------------------|--------------------|-----------------|------------------|
| 8" | 8.00 | 8.00 | 5" | FC23-800-800-05R | 5 | 26 |
| | 8.00 | 8.00 | 7" | FC23-800-800-07R | 5 | 32 |
| | 8.00 | 8.00 | 10" | FC23-800-800-10R | 5 | 39 |
| | 8.00 | 8.63 | 5" | FC23-800-863-05R | 5 | 26 |
| | 8.00 | 8.63 | 7" | FC23-800-863-07R | 5 | 32 |
| | 8.00 | 8.63 | 10" | FC23-800-863-10R | 5 | 39 |
| | 8.00 | 9.05-9.40 | 5" | FC23-800-940-05R | 5 | 26 |
| | 8.00 | 9.05-9.40 | 7" | FC23-800-940-07R | 5 | 32 |
| | 8.00 | 9.05-9.40 | 10" | FC23-800-940-10R | 5 | 39 |
| | 8.00 | 9.40-9.74 | 5" | FC23-800-974-05R | 5 | 26 |
| | 8.00 | 9.40-9.74 | 7" | FC23-800-974-07R | 5 | 32 |
| | 8.00 | 9.40-9.74 | 10" | FC23-800-974-10R | 5 | 39 |
| | 8.63 | 8.63 | 5" | FC23-863-863-05R | 5 | 26 |
| | 8.63 | 8.63 | 7" | FC23-863-863-07R | 5 | 32 |
| | 8.63 | 8.63 | 10" | FC23-863-863-10R | 5 | 39 |
| | 8.63 | 9.05-9.40 | 5" | FC23-863-940-05R | 5 | 26 |
| | 8.63 | 9.05-9.40 | 7" | FC23-863-940-07R | 5 | 32 |
| | 8.63 | 9.05-9.40 | 10" | FC23-863-940-10R | 5 | 39 |
| | 8.63 | 9.40-9.74 | 5" | FC23-863-974-05R | 5 | 26 |
| | 8.63 | 9.40-9.74 | 7" | FC23-863-974-07R | 5 | 32 |
| | 8.63 | 9.40-9.74 | 10" | FC23-863-974-10R | 5 | 39 |
| | 9.05-9.40 | 9.05-9.40 | 5" | FC23-940-940-05R | 5 | 26 |
| | 9.05-9.40 | 9.05-9.40 | 7" | FC23-940-940-07R | 5 | 32 |
| | 9.05-9.40 | 9.05-9.40 | 10" | FC23-940-940-10R | 5 | 39 |
| | 9.05-9.40 | 9.40-9.74 | 5" | FC23-940-974-05R | 5 | 26 |
| | 9.05-9.40 | 9.40-9.74 | 7" | FC23-940-974-07R | 5 | 32 |
| | 9.05-9.40 | 9.40-9.74 | 10" | FC23-940-974-10R | 5 | 39 |
| | 9.40-9.74 | 9.40-9.74 | 5" | FC23-974-974-05R | 5 | 26 |
| | 9.40-9.74 | 9.40-9.74 | 7" | FC23-974-974-07R | 5 | 32 |
| | 9.40-9.74 | 9.40-9.74 | 10" | FC23-974-974-10R | 5 | 39 |
| 10" | 10.75 | 10.75 | 5" | FC23-1075-1075-05R | 6 | 33 |
| | 10.75 | 10.75 | 7" | FC23-1075-1075-07R | 6 | 40 |
| | 10.75 | 10.75 | 10" | FC23-1075-1075-10R | 6 | 49 |
| | 10.75 | 11.10-11.40 | 5" | FC23-1075-1140-05R | 6 | 33 |
| | 10.75 | 11.10-11.40 | 7" | FC23-1075-1140-07R | 6 | 40 |
| | 10.75 | 11.10-11.40 | 10" | FC23-1075-1140-10R | 6 | 49 |
| | 10.75 | 11.42-11.77 | 5" | FC23-1075-1177-05R | 6 | 33 |
| | 10.75 | 11.42-11.77 | 7" | FC23-1075-1177-07R | 6 | 40 |
| | 10.75 | 11.42-11.77 | 10" | FC23-1075-1177-10R | 6 | 49 |
| | 10.75 | 11.77-12.12 | 5" | FC23-1075-1212-05R | 6 | 33 |
| | 10.75 | 11.77-12.12 | 7" | FC23-1075-1212-07R | 6 | 40 |
| | 10.75 | 11.77-12.12 | 10" | FC23-1075-1212-10R | 6 | 49 |
| | 11.10-11.40 | 11.10-11.40 | 5" | FC23-1140-1140-05R | 6 | 33 |
| | 11.10-11.40 | 11.10-11.40 | 7" | FC23-1140-1140-07R | 6 | 40 |
| | 11.10-11.40 | 11.10-11.40 | 10" | FC23-1140-1140-10R | 6 | 49 |
| | 11.10-11.40 | 11.42-11.77 | 5" | FC23-1140-1177-05R | 6 | 33 |
| | 11.10-11.40 | 11.42-11.77 | 7" | FC23-1140-1177-07R | 6 | 40 |
| | 11.10-11.40 | 11.42-11.77 | 10" | FC23-1140-1177-10R | 6 | 49 |
| | 11.10-11.40 | 11.77-12.12 | 5" | FC23-1140-1212-05R | 6 | 33 |
| | 11.10-11.40 | 11.77-12.12 | 7" | FC23-1140-1212-07R | 6 | 40 |
| | 11.10-11.40 | 11.77-12.12 | 10" | FC23-1140-1212-10R | 6 | 49 |
| | 11.42-11.77 | 11.42-11.77 | 5" | FC23-1177-1177-05R | 6 | 33 |
| | 11.42-11.77 | 11.42-11.77 | 7" | FC23-1177-1177-07R | 6 | 40 |
| | 11.42-11.77 | 11.42-11.77 | 10" | FC23-1177-1177-10R | 6 | 49 |
| | 11.42-11.77 | 11.77-12.12 | 5" | FC23-1177-1212-05R | 6 | 33 |
| | 11.42-11.77 | 11.77-12.12 | 7" | FC23-1177-1212-07R | 6 | 40 |
| | 11.42-11.77 | 11.77-12.12 | 10" | FC23-1177-1212-10R | 6 | 49 |
| | 11.77-12.12 | 11.77-12.12 | 5" | FC23-1212-1212-05R | 6 | 33 |
| | 11.77-12.12 | 11.77-12.12 | 7" | FC23-1212-1212-07R | 6 | 40 |
| | 11.77-12.12 | 11.77-12.12 | 10" | FC23-1212-1212-10R | 6 | 49 |

Ford Transition Couplings

Style FC23/FC24 - Fabricated Steel Center Sleeve with Ductile Iron End Rings (4" through 24") *Continued . . .*

| NOM. PIPE SIZE | 1ST END GASKET RANGE | 2ND END GASKET RANGE | LENGTH OF CENTER SLEEVE | CATALOG NUMBER | NUMBER OF BOLTS | APPROX. WT. LBS. | |
|----------------|----------------------|----------------------|-------------------------|--------------------|--------------------|------------------|-----|
| 12" | 12.75 | 12.75 | 5" | FC23-1275-1275-05R | 7 | 42 | |
| | 12.75 | 12.75 | 7" | FC23-1275-1275-07R | 7 | 51 | |
| | 12.75 | 12.75 | 10" | FC23-1275-1275-10R | 7 | 61 | |
| | 12.75 | 13.20-13.50 | 5" | FC23-1275-1350-05R | 7 | 41 | |
| | 12.75 | 13.20-13.50 | 7" | FC23-1275-1350-07R | 7 | 49 | |
| | 12.75 | 13.20-13.50 | 10" | FC23-1275-1350-10R | 7 | 59 | |
| | 12.75 | 13.69-14.04 | 5" | FC23-1275-1404-05R | 7 | 42 | |
| | 12.75 | 13.69-14.04 | 7" | FC23-1275-1404-07R | 7 | 51 | |
| | 12.75 | 13.69-14.04 | 10" | FC23-1275-1404-10R | 7 | 61 | |
| | 12.75 | 14.03-14.38 | 5" | FC23-1275-1438-05R | 7 | 42 | |
| | 12.75 | 14.03-14.38 | 7" | FC23-1275-1438-07R | 7 | 51 | |
| | 12.75 | 14.03-14.38 | 10" | FC23-1275-1438-10R | 7 | 61 | |
| | 13.20-13.50 | 13.20-13.50 | 5" | FC23-1350-1350-05R | 7 | 39 | |
| | 13.20-13.50 | 13.20-13.50 | 7" | FC23-1350-1350-07R | 7 | 48 | |
| | 13.20-13.50 | 13.20-13.50 | 10" | FC23-1350-1350-10R | 7 | 57 | |
| | 13.20-13.50 | 13.69-14.04 | 5" | FC23-1350-1404-05R | 7 | 42 | |
| | 13.20-13.50 | 13.69-14.04 | 7" | FC23-1350-1404-07R | 7 | 51 | |
| | 13.20-13.50 | 13.69-14.04 | 10" | FC23-1350-1404-10R | 7 | 61 | |
| | 13.20-13.50 | 14.03-14.38 | 5" | FC23-1350-1438-05R | 7 | 41 | |
| | 13.20-13.50 | 14.03-14.38 | 7" | FC23-1350-1438-07R | 7 | 50 | |
| | 13.20-13.50 | 14.03-14.38 | 10" | FC23-1350-1438-10R | 7 | 60 | |
| | 13.69-14.04 | 13.69-14.04 | 5" | FC23-1404-1404-05R | 7 | 40 | |
| | 13.69-14.04 | 13.69-14.04 | 7" | FC23-1404-1404-07R | 7 | 49 | |
| | 13.69-14.04 | 13.69-14.04 | 10" | FC23-1404-1404-10R | 7 | 59 | |
| | 13.69-14.04 | 14.03-14.38 | 5" | FC23-1404-1438-05R | 7 | 39 | |
| | 13.69-14.04 | 14.03-14.38 | 7" | FC23-1404-1438-07R | 7 | 48 | |
| | 13.69-14.04 | 14.03-14.38 | 10" | FC23-1404-1438-10R | 7 | 58 | |
| | 14.03-14.38 | 14.03-14.38 | 5" | FC23-1438-1438-05R | 7 | 39 | |
| 14.03-14.38 | 14.03-14.38 | 7" | FC23-1438-1438-07R | 7 | 49 | | |
| 14.03-14.38 | 14.03-14.38 | 10" | FC23-1438-1438-10R | 7 | 58 | | |
| 14" | 15.30-15.70 | 15.30-15.70 | 5" | FC23-1570-1570-05R | 9 | 66 | |
| | 15.30-15.70 | 15.30-15.70 | 7" | FC23-1570-1570-07R | 9 | 71 | |
| | 15.30-15.70 | 15.30-15.70 | 10" | FC23-1570-1570-10R | 9 | 85 | |
| | 15.30-15.70 | 16.00-16.35 | 5" | FC23-1570-1635-05R | 9 | 58 | |
| | 15.30-15.70 | 16.00-16.35 | 7" | FC23-1570-1635-07R | 9 | 68 | |
| | 15.30-15.70 | 16.00-16.35 | 10" | FC23-1570-1635-10R | 9 | 82 | |
| | 15.30-15.70 | 16.40-16.88 | 5" | FC23-1570-1688-05R | 9 | 59 | |
| | 15.30-15.70 | 16.40-16.88 | 7" | FC23-1570-1688-07R | 9 | 70 | |
| | 15.30-15.70 | 16.40-16.88 | 10" | FC23-1570-1688-10R | 9 | 83 | |
| | 16.00-16.35 | 16.00-16.35 | 5" | FC23-1635-1635-05R | 9 | 55 | |
| | 16.00-16.35 | 16.00-16.35 | 7" | FC23-1635-1635-07R | 9 | 66 | |
| | 16.00-16.35 | 16.00-16.35 | 10" | FC23-1635-1635-10R | 9 | 80 | |
| | 16.00-16.35 | 16.40-16.88 | 5" | FC23-1635-1688-05R | 9 | 56 | |
| | 16.00-16.35 | 16.40-16.88 | 7" | FC23-1635-1688-07R | 9 | 67 | |
| | 16.00-16.35 | 16.40-16.88 | 10" | FC23-1635-1688-10R | 9 | 80 | |
| | 16.40-16.88 | 16.40-16.88 | 5" | FC23-1688-1688-05R | 9 | 57 | |
| | 16.40-16.88 | 16.40-16.88 | 7" | FC23-1688-1688-07R | 9 | 68 | |
| | 16.40-16.88 | 16.40-16.88 | 10" | FC23-1688-1688-10R | 9 | 81 | |
| | 16" | 17.40-17.80 | 17.40-17.80 | 5" | FC23-1780-1780-05R | 10 | 76 |
| | | 17.40-17.80 | 17.40-17.80 | 7" | FC23-1780-1780-07R | 10 | 88 |
| 17.40-17.80 | | 17.40-17.80 | 10" | FC23-1780-1780-10R | 10 | 102 | |
| 17.40-17.80 | | 18.45-18.97 | 5" | FC23-1780-1897-05R | 10 | 71 | |
| 17.40-17.80 | | 18.45-18.97 | 7" | FC23-1780-1897-07R | 10 | 83 | |
| 17.40-17.80 | | 18.45-18.97 | 10" | FC23-1780-1897-10R | 10 | 98 | |
| 17.40-17.80 | | 18.90-19.20 | 5" | FC23-1780-1920-05R | 10 | 73 | |
| 17.40-17.80 | | 18.90-19.20 | 7" | FC23-1780-1920-07R | 10 | 85 | |
| 17.40-17.80 | | 18.90-19.20 | 10" | FC23-1780-1920-10R | 10 | 99 | |
| 18.45-18.97 | | 18.45-18.97 | 5" | FC23-1897-1897-05R | 10 | 72 | |
| 18.45-18.97 | | 18.45-18.97 | 7" | FC23-1897-1897-07R | 10 | 84 | |
| 18.45-18.97 | | 18.45-18.97 | 10" | FC23-1897-1897-10R | 10 | 98 | |
| 18.45-18.97 | | 18.90-19.20 | 5" | FC23-1897-1920-05R | 10 | 71 | |
| 18.45-18.97 | | 18.90-19.20 | 7" | FC23-1897-1920-07R | 10 | 84 | |
| 18.45-18.97 | | 18.90-19.20 | 10" | FC23-1897-1920-10R | 10 | 98 | |
| 18.90-19.20 | | 18.90-19.20 | 5" | FC23-1920-1920-05R | 10 | 71 | |
| 18.90-19.20 | | 18.90-19.20 | 7" | FC23-1920-1920-07R | 10 | 83 | |
| 18.90-19.20 | | 18.90-19.20 | 10" | FC23-1920-1920-10R | 10 | 97 | |
| 18" | | 19.50-20.00 | 19.50-20.00 | 7" | FC23-2000-2000-07R | 11 | 88 |
| | | 19.50-20.00 | 19.50-20.00 | 10" | FC23-2000-2000-10R | 11 | 103 |
| 20" | 21.60-22.06 | 21.60-22.06 | 7" | FC23-2206-2206-07R | 12 | 99 | |
| | 21.60-22.06 | 21.60-22.06 | 10" | FC23-2206-2206-10R | 12 | 119 | |
| 24" | 25.80-26.32 | 25.80-26.32 | 7" | FC23-2632-2632-07R | 14 | 168 | |
| | 25.80-26.32 | 25.80-26.32 | 10" | FC23-2632-2632-10R | 14 | 185 | |

See page 2 index for larger couplings.

Ford Standard Steel Couplings

Style FC3 (1/2" through 12")

The FC3 coupling is manufactured in standard steel sizes with a steel center sleeve and ductile iron end rings and complies with DOT Regulation Part 192 Title 49. The FC3, in its standard configuration, may be used for water as well as natural gas applications.

Finish - Red Armorguard e-coat on end rings
Black fusion-bonded epoxy on center sleeve with Armorguard e-coat undercoat

Rated Working Pressure - 200 psi

End Rings - Ductile iron (Grade 65-45-12) per ASTM A536

Center Sleeve - Steel per ASTM A1011

Gaskets - Buna-N (NBR)
 Optional: - Armor-tip gasket (-ATG)

Bolts and Nuts - High strength low alloy steel per ASTM A242
 Optional stainless steel or blue fluorocarbon-coated hardware

**Caution: Couplings do not restrain axial pipe movement.
 Unbalanced forces created by internal water pressure or external forces must be restrained.**

How to order FC3 couplings:

Use catalog numbers from the next page. For example, an FC3 steel coupling with a center sleeve length of 7" for pipe with an O.D. of 2.88 would be an FC3-288-7.

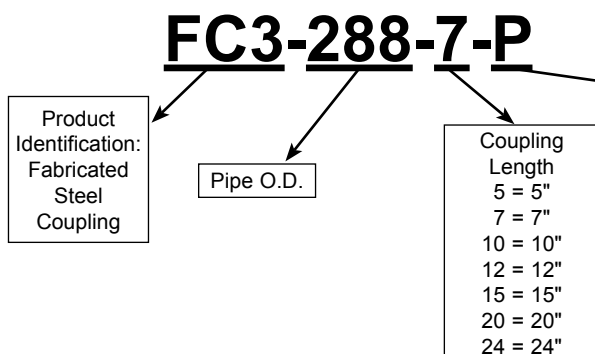

| COATING, BOLTS AND GASKET OPTIONS | | | | |
|-----------------------------------|----------------------|---------------------------|---------------------------|--------------------------|
| EPOXY COATED | | | | |
| COATING AND BOLT COMBINATIONS | | | | |
| GASKET MATERIAL | Standard Alloy Bolts | 304 Stainless Steel Bolts | 316 Stainless Steel Bolts | Electro-Galvanized Bolts |
| Buna-N Rubber | (no suffix) | P | T | O |

Ford Standard Steel Couplings

Style FC3

Style FC3 Standard Steel Couplings - 1/2" through 12"

| NOM. PIPE SIZE | PIPE O.D. | SLEEVE THICKNESS & LENGTH | CATALOG NUMBER | NUMBER OF BOLTS | BOLT DIA. & LENGTH | APPROX. WT. LBS. |
|----------------|-----------|---------------------------|----------------|-----------------|--------------------|------------------|
| 1/2" | .84 | .120x5" | FC3-084-5 | 2 | 1/2"x7" | 2 |
| | | .120x7" | FC3-084-7 | 2 | 1/2"x9" | 2 |
| 3/4" | 1.05 | .120x5" | FC3-105-5 | 2 | 1/2"x7" | 2 |
| | | .120x7" | FC3-105-7 | 2 | 1/2"x9" | 3 |
| | | .120x12" | FC3-105-12 | 2 | 1/2"x14" | 3 |
| 1" | 1.32 | .120x5" | FC3-132-5 | 2 | 1/2"x7" | 3 |
| | | .120x7" | FC3-132-7 | 2 | 1/2"x9" | 3 |
| | | .120x12" | FC3-132-12 | 2 | 1/2"x14" | 4 |
| 1-1/4" | 1.66 | .134x5" | FC3-166-5 | 2 | 1/2"x7" | 4 |
| | | .134x7" | FC3-166-7 | 2 | 1/2"x9" | 4 |
| | | .134x12" | FC3-166-12 | 2 | 1/2"x14" | 5 |
| 1-1/2" | 1.90 | .134x5" | FC3-190-5 | 2 | 1/2"x7" | 4 |
| | | .134x7" | FC3-190-7 | 2 | 1/2"x9" | 5 |
| | | .134x12" | FC3-190-12 | 2 | 1/2"x14" | 7 |
| 2" | 2.38 | .156x5" | FC3-238-5 | 2 | 5/8"x8" | 7 |
| | | .156x5" | FC3-238-5-H | 3 | 5/8"x8" | 10 |
| | | .156x7" | FC3-238-7 | 2 | 5/8"x11" | 10 |
| | | .156x7" | FC3-238-7-H | 3 | 5/8"x11" | 12 |
| | | .156x12" | FC3-238-12 | 2 | 5/8"x15" | 13 |
| 2-1/2" | 2.88 | .156x12" | FC3-238-12-H | 3 | 5/8"x15" | 14 |
| | | .156x5" | FC3-288-5 | 3 | 5/8"x9" | 10 |
| | | .156x7" | FC3-288-7 | 3 | 5/8"x11" | 11 |
| | | .156x12" | FC3-288-12 | 3 | 5/8"x15" | 14 |
| 3" | 3.50 | .156x24" | FC3-288-24 | 3 | 5/8"x27" | 24 |
| | | .203x5" | FC3-350-5 | 4 | 5/8"x9" | 16 |
| | | .203x7" | FC3-350-7 | 4 | 5/8"x11" | 17 |
| | | .203x12" | FC3-350-12 | 4 | 5/8"x15" | 26 |
| 4" | 4.50 | .203x24" | FC3-350-24 | 4 | 5/8"x27" | 35 |
| | | .203x5" | FC3-450-5 | 4 | 5/8"x9" | 16 |
| | | .203x7" | FC3-450-7 | 4 | 5/8"x11" | 17 |
| | | .203x12" | FC3-450-12 | 4 | 5/8"x15" | 27 |
| | 4.80 | .203x16" | FC3-450-16 | 4 | 5/8"x19" | 31 |
| | | .203x24" | FC3-450-24 | 4 | 5/8"x27" | 38 |
| | | .203x5" | FC3-480-5 | 4 | 5/8"x9" | 16 |
| | | .203x7" | FC3-480-7 | 4 | 5/8"x11" | 17 |
| 6" | 6.63 | .203x12" | FC3-480-12 | 4 | 5/8"x15" | 27 |
| | | .203x16" | FC3-480-16 | 4 | 5/8"x19" | 31 |
| | | .203x24" | FC3-480-24 | 4 | 5/8"x27" | 38 |
| | | .250x5" | FC3-663-5 | 6 | 5/8"x9" | 25 |
| | 6.90 | .250x7" | FC3-663-7 | 6 | 5/8"x11" | 31 |
| | | .250x12" | FC3-663-12 | 6 | 5/8"x15" | 39 |
| | | .250x16" | FC3-663-16 | 6 | 5/8"x19" | 50 |
| | | .250x24" | FC3-663-24 | 6 | 5/8"x27" | 65 |
| 8" | 8.63 | .250x5" | FC3-690-5 | 6 | 5/8"x8" | 25 |
| | | .250x16" | FC3-690-16 | 6 | 5/8"x19" | 50 |
| | | .250x5" | FC3-863-5 | 6 | 5/8"x8" | 34 |
| | | .250x7" | FC3-863-7 | 6 | 5/8"x11" | 41 |
| | 9.05 | .250x12" | FC3-863-12 | 6 | 5/8"x15" | 51 |
| | | .250x16" | FC3-863-16 | 6 | 5/8"x19" | 63 |
| | | .250x24" | FC3-863-24 | 6 | 5/8"x27" | 78 |
| | | .250x5" | FC3-905-5 | 6 | 5/8"x9" | 34 |
| 10" | 10.75 | .250x7" | FC3-905-7 | 6 | 5/8"x11" | 41 |
| | | .250x16" | FC3-905-16 | 6 | 5/8"x19" | 63 |
| | | .250x5" | FC3-1075-5 | 8 | 5/8"x9" | 41 |
| 12" | 12.75 | .250x7" | FC3-1075-7 | 8 | 5/8"x11" | 49 |
| | | .250x16" | FC3-1075-16 | 8 | 5/8"x19" | 67 |
| | | .250x5" | FC3-1275-5 | 8 | 5/8"x9" | 47 |
| | | .250x7" | FC3-1275-7 | 8 | 5/8"x11" | 53 |
| | | .250x16" | FC3-1275-16 | 8 | 5/8"x19" | 88 |

"-H" indicates three bolt style

Note: Larger sizes are detailed as style FC4 on pages 15 and 16.

Ford Steel Couplings

Style FC4 (14" through 60")

The Ford FC4 Steel Coupling is an all steel coupling designed to connect various types of plain end pipe with the same O.D. and is available for pipe sizes up to a maximum nominal diameter of 60 inches. Design and performance characteristics of fabricated steel couplings are specified in AWWA Standard C219. The Style FC4 Coupling is available in a variety of center sleeve lengths and thicknesses.

Bolts and Nuts - High strength low alloy steel ASTM A242 and AWWA C111
 Optional: - Type 304 stainless steel
 - Type 316 stainless steel
 - Electro-galvanized steel
 - Blue Fluorocarbon coating

Center Sleeve - ASTM A36 carbon Steel

Finish - Black shop coat
 Optional: - Epoxy coating

Gaskets - SBR Rubber
 Optional: - Buna-N
 - EPDM

End Rings - AISI 1018-1020 cold rolled or extruded carbon steel

Caution: Flexible couplings do not restrain axial pipe movement. Unbalanced forces created by internal water pressure or external forces must be restrained. Restrained couplings using Uni-Flange restraints can be found in Catalog Section U. Contact factory for details.

How to order FC4 couplings:

Our code system is used to designate the part number. Each code determines how the coupling will be manufactured. The coupling center sleeve thickness and length is generally determined by the pipe O.D. and the working pressure. Ford will manufacture FC4 couplings to your specifications using the material and dimensional parameters listed below. **Before ordering a special pipe O.D., make sure your O.D. is not listed in the table on page N-15 or N-16.**

The example shown below is an FC4-5140-B10R. This coupling is made to fit a pipe with an O.D. of 51.40 inches. It is manufactured using a 3/8" by 10" steel center sleeve and standard bolts, and is finished with a standard shop coat. For coupling length, coating and bolt options not listed on the following charts, select the proper catalog number to accommodate your pipe O.D. and substitute the desired option codes listed below.

FC4-5140-B 10 R

Product Identification:
Fabricated Steel Coupling

Pipe O.D.

Center Sleeve Thickness
A = 1/4" Steel
B = 3/8" Steel

Coupling Length
05 = 5"
07 = 7"
10 = 10"
12 = 12"
15 = 15"
20 = 20"
24 = 24"

| COATING, BOLTS AND GASKET OPTIONS | | | | |
|-----------------------------------|----------------------|---------------------------|---------------------------|--------------------------|
| COATING AND BOLT COMBINATIONS | | | | |
| GASKET MATERIAL | Standard Alloy Bolts | 304 Stainless Steel Bolts | 316 Stainless Steel Bolts | Electro Galvanized Bolts |
| Standard Shop Coat | | | | |
| SBR Rubber | R | X | Q | G |
| Buna-N Rubber | N | H | J | F |
| EPDM Rubber | S | M | V | W |
| Epoxy Coated | | | | |
| SBR Rubber | E | Y | Z | K |
| Buna-N Rubber | C | P | T | O |
| EPDM Rubber | A | B | D | L |

Note: See item listings in catalog section to assure that desired sizes and options are available

Ford Steel Couplings

Style FC4 (14" through 60")

Listed below are common sizes of FC4 couplings.

If your pipe O.D. is not in the listed ranges, insert the exact O.D. into the code system to create your own catalog number (see the previous page).

| NOM. PIPE SIZE | PIPE O.D. | SLEEVE THICKNESS & LENGTH | CATALOG NUMBER | RATED WORKING PRESSURE | NUMBER OF BOLTS | APPROX. WT. LBS. |
|----------------|------------|---------------------------|----------------|------------------------|-----------------|------------------|
| 14" | 14.00 | 1/4" x 5" | FC4-1400-A05R | 472 | 9 | 70 |
| | 14.00 | 1/4" x 7" | FC4-1400-A07R | 472 | 9 | 75 |
| | 14.00 | 1/4" x 10" | FC4-1400-A10R | 472 | 9 | 85 |
| | 15.30 | 1/4" x 5" | FC4-1530-A05R | 434 | 9 | 75 |
| | 15.30 | 1/4" x 7" | FC4-1530-A07R | 434 | 9 | 80 |
| | 15.30 | 3/8" x 7" | FC4-1530-B07R | 592 | 9 | 92 |
| | 15.30 | 1/4" x 10" | FC4-1530-A10R | 434 | 9 | 91 |
| | 15.30 | 3/8" x 10" | FC4-1530-B10R | 592 | 9 | 109 |
| | 15.65 | 3/8" x 7" | FC4-1565-B07R | 583 | 9 | 92 |
| 15.65 | 3/8" x 10" | FC4-1565-B10R | 583 | 9 | 109 | |
| 16" | 16.00 | 1/4" x 5" | FC4-1600-A05R | 416 | 10 | 78 |
| | 16.00 | 1/4" x 7" | FC4-1600-A07R | 416 | 10 | 83 |
| | 16.00 | 1/4" x 10" | FC4-1600-A10R | 416 | 10 | 96 |
| | 17.40 | 1/4" x 5" | FC4-1740-A05R | 385 | 10 | 84 |
| | 17.40 | 1/4" x 7" | FC4-1740-A07R | 385 | 10 | 89 |
| | 17.40 | 3/8" x 7" | FC4-1740-B07R | 567 | 10 | 103 |
| | 17.40 | 1/4" x 10" | FC4-1740-A10R | 385 | 10 | 102 |
| | 17.40 | 3/8" x 10" | FC4-1740-B10R | 567 | 10 | 122 |
| | 17.80 | 3/8" x 7" | FC4-1780-B07R | 540 | 10 | 103 |
| 17.80 | 1/4" x 7" | FC4-1780-A07R | 372 | 10 | 92 | |
| 18" | 18.00 | 1/4" x 5" | FC4-1800-A05R | 373 | 11 | 89 |
| | 18.00 | 1/4" x 7" | FC4-1800-A07R | 373 | 11 | 94 |
| | 18.00 | 1/4" x 10" | FC4-1800-A10R | 373 | 11 | 107 |
| | 18.80 | 3/8" x 7" | FC4-1880-B07R | 508 | 11 | 112 |
| | 18.80 | 1/4" x 7" | FC4-1880-A07R | 355 | 11 | 100 |
| | 19.50 | 1/4" x 5" | FC4-1950-A05R | 345 | 11 | 94 |
| | 19.50 | 1/4" x 7" | FC4-1950-A07R | 345 | 11 | 99 |
| | 19.50 | 3/8" x 7" | FC4-1950-B07R | 512 | 11 | 115 |
| | 19.50 | 1/4" x 10" | FC4-1950-A10R | 345 | 11 | 114 |
| 19.50 | 3/8" x 10" | FC4-1950-B10R | 512 | 11 | 136 | |
| 19.92 | 3/8" x 7" | FC4-1992-B07R | 500 | 11 | 115 | |
| 19.92 | 1/4" x 7" | FC4-1992-A07R | 337 | 11 | 104 | |
| 20" | 20.00 | 1/4" x 7" | FC4-2000-A07R | 337 | 12 | 101 |
| | 20.00 | 1/4" x 10" | FC4-2000-A10R | 337 | 12 | 116 |
| | 21.60 | 1/4" x 7" | FC4-2160-A07R | 313 | 12 | 107 |
| | 21.60 | 3/8" x 7" | FC4-2160-B07R | 463 | 12 | 125 |
| | 21.60 | 1/4" x 10" | FC4-2160-A10R | 313 | 12 | 124 |
| | 21.60 | 3/8" x 10" | FC4-2160-B10R | 463 | 12 | 148 |
| | 22.06 | 3/8" x 7" | FC4-2206-B07R | 456 | 12 | 125 |
| 22.06 | 1/4" x 7" | FC4-2206-A07R | 307 | 12 | 110 | |
| 24" | 24.00 | 1/4" x 7" | FC4-2400-A07R | 283 | 14 | 119 |
| | 24.00 | 1/4" x 10" | FC4-2400-A10R | 283 | 14 | 137 |
| | 25.80 | 1/4" x 7" | FC4-2580-A07R | 264 | 14 | 127 |
| | 25.80 | 3/8" x 7" | FC4-2580-B07R | 392 | 14 | 148 |
| | 25.80 | 1/4" x 10" | FC4-2580-A10R | 264 | 14 | 146 |
| | 25.80 | 3/8" x 10" | FC4-2580-B10R | 392 | 14 | 176 |
| | 26.32 | 3/8" x 7" | FC4-2632-B07R | 377 | 14 | 148 |
| 26.32 | 1/4" x 7" | FC4-2632-A07R | 250 | 14 | 135 | |

Ford Steel Couplings

Style FC4 (14" through 60") *Continued . . .*

Listed below are common sizes of FC4 couplings.

If your pipe O.D. is not listed, insert the exact O.D. into the code system to create your own catalog number (see page 14).

| NOM. PIPE SIZE | PIPE O.D. | SLEEVE THICKNESS & LENGTH | CATALOG NUMBER | RATED WORKING PRESSURE | NUMBER OF BOLTS | APPROX. WT. LBS. |
|----------------|------------|---------------------------|----------------|------------------------|-----------------|------------------|
| 30" | 30.00 | 1/4" x 7" | FC4-3000-A07R | 246 | 16 | 135 |
| | 30.00 | 3/8" x 7" | FC4-3000-B07R | 361 | 16 | 159 |
| | 30.00 | 1/4" x 10" | FC4-3000-A10R | 246 | 16 | 157 |
| | 30.00 | 3/8" x 10" | FC4-3000-B10R | 361 | 16 | 189 |
| | 32.00 | 1/4" x 7" | FC4-3200-A07R | 230 | 16 | 143 |
| | 32.00 | 3/8" x 7" | FC4-3200-B07R | 343 | 16 | 166 |
| | 32.00 | 1/4" x 10" | FC4-3200-A10R | 230 | 16 | 166 |
| 36" | 32.00 | 3/8" x 10" | FC4-3200-B10R | 343 | 16 | 201 |
| | 36.00 | 1/4" x 7" | FC4-3600-A07R | 205 | 18 | 158 |
| | 36.00 | 3/8" x 7" | FC4-3600-B07R | 306 | 18 | 190 |
| | 36.00 | 1/4" x 10" | FC4-3600-A10R | 205 | 18 | 186 |
| | 36.00 | 3/8" x 10" | FC4-3600-B10R | 306 | 18 | 229 |
| | 38.30 | 1/4" x 7" | FC4-3830-A07R | 193 | 18 | 166 |
| | 38.30 | 3/8" x 7" | FC4-3830-B07R | 289 | 18 | 226 |
| 42" | 38.30 | 1/4" x 10" | FC4-3830-A10R | 193 | 18 | 196 |
| | 38.30 | 3/8" x 10" | FC4-3830-B10R | 289 | 18 | 267 |
| | 42.00 | 3/8" x 7" | FC4-4200-B07R | 263 | 20 | 257 |
| | 42.00 | 3/8" x 10" | FC4-4200-B10R | 263 | 20 | 302 |
| | 44.50 | 3/8" x 7" | FC4-4450-B07R | 250 | 20 | 271 |
| | 44.50 | 3/8" x 10" | FC4-4450-B10R | 250 | 20 | 318 |
| | 48" | 48.00 | 3/8" x 7" | FC4-4800-B07R | 231 | 22 |
| 48.00 | | 3/8" x 10" | FC4-4800-B10R | 231 | 22 | 345 |
| 49.00 | | 3/8" x 7" | FC4-4900-B07R | 226 | 22 | 300 |
| 49.00 | | 3/8" x 10" | FC4-4900-B10R | 226 | 22 | 351 |
| 50.80 | | 3/8" x 7" | FC4-5080-B07R | 220 | 22 | 309 |
| 50.80 | | 3/8" x 10" | FC4-5080-B10R | 220 | 22 | 363 |
| 54" | 54.00 | 3/8" x 7" | FC4-5400-B07R | 213 | 24 | 333 |
| | 54.00 | 3/8" x 10" | FC4-5400-B10R | 213 | 24 | 391 |
| | 55.00 | 3/8" x 7" | FC4-5500-B07R | 210 | 24 | 339 |
| | 55.00 | 3/8" x 10" | FC4-5500-B10R | 210 | 24 | 398 |
| | 57.10 | 3/8" x 7" | FC4-5710-B07R | 200 | 24 | 350 |
| | 57.10 | 3/8" x 10" | FC4-5710-B10R | 200 | 24 | 411 |
| | 57.56 | 3/8" x 7" | FC4-5756-B07R | 200 | 24 | 353 |
| | 57.56 | 3/8" x 10" | FC4-5756-B10R | 200 | 24 | 414 |
| | 57.80 | 3/8" x 7" | FC4-5780-B07R | 200 | 24 | 354 |
| 57.80 | 3/8" x 10" | FC4-5780-B10R | 200 | 24 | 415 | |
| 60" | 60.00 | 3/8" x 7" | FC4-6000-B07R | 200 | 26 | 373 |
| | 60.00 | 3/8" x 10" | FC4-6000-B10R | 200 | 26 | 437 |
| | 61.00 | 3/8" x 7" | FC4-6100-B07R | 200 | 26 | 378 |
| | 61.00 | 3/8" x 10" | FC4-6100-B10R | 200 | 26 | 444 |
| | 61.61 | 3/8" x 7" | FC4-6161-B07R | 200 | 26 | 382 |
| | 61.61 | 3/8" x 10" | FC4-6161-B10R | 200 | 26 | 447 |
| | 63.40 | 3/8" x 7" | FC4-6340-B07R | 200 | 26 | 391 |
| 63.40 | 3/8" x 10" | FC4-6340-B10R | 200 | 26 | 459 | |

Ford Steel End Cap Couplings

Style FC4 – with Tapped or Untapped End Cap

The typical use of an FC4 End Cap Coupling is to provide a temporary end or air relief for a pipeline. The end cap is welded to the center sleeve and can be manufactured with a 2" female iron pipe tap if specified. Tapped end cap couplings are supplied less plug but a plug is available upon request. If a smaller end cap coupling is required, refer to cast couplings listed in catalog section M.

End cap couplings require thrust restraint to prevent the coupling from blowing off of the pipe end. Ford can manufacture the Style FC4 End Cap Coupling with anchor studs or with restrainer assemblies to meet this requirement.

Bolts and Nuts - High strength low alloy steel ASTM A242 and AWWA C111

Optional: - Type 304 stainless steel
 - Type 316 stainless steel
 - Electro-galvanized steel
 - Blue Fluorocarbon coating

Gasket - SBR Rubber

Optional: - Buna-N
 - EPDM

Center Sleeve - ASTM A36 carbon steel

End Ring - AISI 1018-1020 cold rolled, or extruded carbon steel



Standard Location

Optional: Center location

Finish - Black shop coat

Optional: - Fusion bonded epoxy

Caution: Proper installation of end cap couplings must include the use of a thrust restraint device.

Listed below are common sizes of FC4 couplings.

| NOM. PIPE SIZE | PIPE O.D. | SLEEVE THICKNESS & LENGTH | CATALOG NUMBER | RATED WORKING PRESSURE | NUMBER OF BOLTS | APPROX. Wt. LBS. |
|----------------|-----------|---------------------------|-------------------|------------------------|-----------------|------------------|
| 14" | 14.00 | 1/4" x 5" | FC4-1400-A05R-TEC | 150 | 9 | 81 |
| | 14.00 | 1/4" x 7" | FC4-1400-A07R-TEC | 150 | 9 | 86 |
| | 14.00 | 3/8" x 7" | FC4-1400-B07R-BEC | 150 | 9 | 84 |
| | 15.30 | 1/4" x 7" | FC4-1530-A07R-TEC | 150 | 9 | 95 |
| | 15.30 | 3/8" x 7" | FC4-1530-B07R-BEC | 150 | 9 | 93 |
| | 15.65 | 3/8" x 7" | FC4-1565-B07R-TEC | 150 | 9 | 104 |
| 16" | 16.00 | 1/4" x 5" | FC4-1600-A05R-TEC | 150 | 10 | 108 |
| | 16.00 | 1/4" x 7" | FC4-1600-A07R-TEC | 150 | 10 | 114 |
| | 16.00 | 3/8" x 7" | FC4-1600-B07R-BEC | 150 | 10 | 112 |
| | 17.40 | 1/4" x 7" | FC4-1740-A07R-TEC | 150 | 10 | 127 |
| | 17.40 | 3/8" x 7" | FC4-1740-B07R-BEC | 150 | 10 | 125 |
| 18" | 17.80 | 3/8" x 7" | FC4-1780-B07R-TEC | 150 | 10 | 130 |
| | 18.00 | 1/4" x 5" | FC4-1800-A05R-TEC | 150 | 11 | 127 |
| | 18.00 | 1/4" x 7" | FC4-1800-A07R-TEC | 150 | 11 | 134 |
| | 18.00 | 3/8" x 7" | FC4-1800-B07R-BEC | 150 | 11 | 132 |
| | 19.50 | 1/4" x 7" | FC4-1950-A07R-TEC | 150 | 11 | 157 |
| | 19.50 | 3/8" x 7" | FC4-1950-B07R-BEC | 150 | 11 | 155 |
| 20" | 19.92 | 3/8" x 7" | FC4-1992-B07R-TEC | 150 | 11 | 173 |
| | 20.00 | 1/4" x 7" | FC4-2000-A07R-TEC | 150 | 12 | 173 |
| | 20.00 | 3/8" x 7" | FC4-2000-B07R-BEC | 150 | 12 | 171 |
| | 21.60 | 1/4" x 7" | FC4-2160-A07R-TEC | 150 | 12 | 192 |
| | 21.60 | 3/8" x 7" | FC4-2160-B07R-BEC | 150 | 12 | 190 |
| 24" | 22.06 | 3/8" x 7" | FC4-2206-B07R-TEC | 150 | 12 | 197 |
| | 24.00 | 1/4" x 7" | FC4-2400-A07R-TEC | 150 | 14 | 252 |
| | 24.00 | 3/8" x 7" | FC4-2400-B07R-BEC | 150 | 14 | 250 |
| | 25.80 | 1/4" x 7" | FC4-2580-A07R-TEC | 150 | 14 | 280 |
| | 25.80 | 3/8" x 7" | FC4-2580-B07R-BEC | 150 | 14 | 278 |
| | 26.32 | 3/8" x 7" | FC4-2632-B07R-TEC | 150 | 14 | 296 |

Note: End caps are optional with any FC4 coupling shown on pages 15 or 16. To order, add "-TEC" (tapped end cap code) or "-BEC" (blind end cap code) to the FC4 part number.

Ford Steel Transition Couplings

Style FC5

The Ford FC5 Transition Coupling is an all steel product designed to connect plain end pipes with different OD's. When ordering, use the table shown on the next page or use the exact O.D. measurements of the two pipes to be joined. The numbering system chart below shows how to order an FC5 coupling for your specific needs. Generally, the maximum differential between two pipes to be joined may not exceed 1" except as listed. For pipes with a measured differential of more than 1", refer to Ford FC6 Steel Reducing Couplings on page 20.

Bolts and Nuts - High strength low alloy steel per ASTM A242 and AWWA C111
 Optional: - Type 304 stainless steel
 - Type 316 stainless steel
 - Electro-galvanized steel
 - Blue Fluorocarbon coating

Gaskets - SBR extruded or molded rubber
 Optional: - Buna-N
 - EPDM

Center Sleeve - ASTM A36 carbon steel

End Rings - AISI 1018-1020 cold rolled or extruded carbon steel

Finish - Black shop coat
 Optional: - Epoxy coating



**Caution: Flexible couplings do not restrain axial pipe movement.
 Unbalanced forces created by internal water pressure or external forces must be properly restrained.**

How to order FC5 Couplings:

Our code system is used to designate the part number. Each code determines how the coupling will be manufactured. The example shown below is an FC5-2580-2632-B15R. This steel coupling is made to couple a 25.80 O.D. pipe to a 26.32 O.D. pipe using 3/8" by 15" long steel center sleeve, SBR gaskets, standard nuts and bolts and would be painted with our standard shop coat.

FC5-2580-2632-B 15 R

Product Identification:
Fabricated Steel Transition Coupling

Small End Pipe O.D.

Large End Pipe O.D.

Center Sleeve Thickness
A = 1/4" Steel
B = 3/8" Steel

Coupling Length
10 = 10"
12 = 12"
15 = 15"
20 = 20"
24 = 24"

| COATING, BOLTS AND GASKET OPTIONS | | | | |
|-----------------------------------|-------------------------------|---------------------------|---------------------------|--------------------------|
| GASKET MATERIAL | COATING AND BOLT COMBINATIONS | | | |
| | Standard Alloy Bolts | 304 Stainless Steel Bolts | 316 Stainless Steel Bolts | Electro Galvanized Bolts |
| Standard Shop Coat | | | | |
| SBR Rubber | R | X | Q | G |
| Buna-N Rubber | N | H | J | F |
| EPDM Rubber | S | M | V | W |
| Epoxy Coated | | | | |
| SBR Rubber | E | Y | Z | K |
| Buna-N Rubber | C | P | T | O |
| EPDM Rubber | A | B | D | L |

Note: See item listings in catalog section to assure that desired sizes and options are available

Ford Steel Transition Couplings

Style FC5

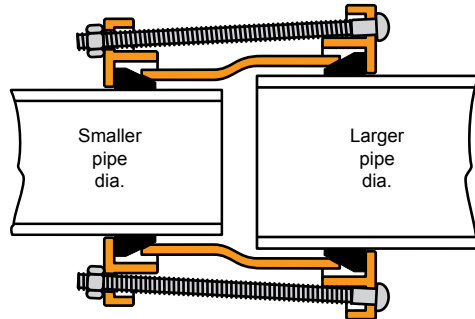

**DESIGN CONFIGURATION FOR FC5
TRANSITION COUPLING**

Listed below are the common sizes of FC5 couplings.

If your pipe O.D. is not in the listed ranges, use the code number system on the previous page to create your catalog number. Remember that the diameters of the two pipes to be joined may not vary more than 1" except as listed. For larger variations, please refer to FC6 coupling information on page 20. Smaller sizes are shown as style FC23 on pages 8 through 11.

| NOMINAL PIPE SIZE | 1ST END GASKET RANGE | 2ND END GASKET RANGE | CENTER SLEEVE INFORMATION | CATALOG NUMBER | NUMBER OF BOLTS | RATED WORKING PRESSURE | APPROX. WT. LBS. |
|-------------------|----------------------|----------------------|---------------------------|--------------------|-----------------|------------------------|------------------|
| 14" | 14.00 | 15.30 | 1/4" X 10" | FC5-1400-1530-A10R | 9 | 200 | 85 |
| | 15.30 | 15.65 | 1/4" x 10" | FC5-1530-1565-A10R | 9 | 416 | 91 |
| | 15.30 | 15.98 | 1/4" x 10" | FC5-1530-1598-A10R | 9 | 416 | 96 |
| | 15.30 | 16.22 | 1/4" x 10" | FC5-1530-1622-A10R | 9 | 410 | 97 |
| 16" | 16.00 | 17.40 | 1/4" X 10" | FC5-1600-1740-A10R | 10 | 200 | 96 |
| | 17.40 | 17.80 | 1/4" x 10" | FC5-1740-1780-A10R | 10 | 372 | 102 |
| | 17.40 | 17.94 | 1/4" x 10" | FC5-1740-1794-A10R | 10 | 372 | 107 |
| | 17.40 | 18.16 | 1/4" x 10" | FC5-1740-1816-A10R | 10 | 372 | 107 |
| 18" | 18.00 | 19.50 | 1/4" X 10" | FC5-1800-1950-A10R | 11 | 200 | 109 |
| | 19.50 | 19.92 | 1/4" x 10" | FC5-1950-1992-A10R | 11 | 337 | 114 |
| 20" | 20.00 | 21.60 | 1/4" X 10" | FC5-2000-2160-A10R | 12 | 200 | 116 |
| | 21.60 | 22.06 | 1/4" x 10" | FC5-2160-2206-A10R | 12 | 313 | 124 |
| | 21.60 | 22.50 | 1/4" x 10" | FC5-2160-2250-A10R | 12 | 313 | 124 |
| 24" | 24.00 | 25.80 | 1/4" X 10" | FC5-2400-2580-A10R | 14 | 200 | 137 |
| | 25.80 | 26.32 | 1/4" x 10" | FC5-2580-2632-A10R | 14 | 250 | 146 |
| | 25.80 | 26.48 | 1/4" x 10" | FC5-2580-2648-A10R | 14 | 250 | 146 |
| 30" | 30.00 | 32.00 | 1/4" X 10" | FC5-3000-3200-A10R | 16 | 200 | 157 |
| | 31.74 | 32.00 | 1/4" x 10" | FC5-3174-3200-A10R | 16 | 230 | 165 |
| | 32.00 | 32.40 | 1/4" x 10" | FC5-3200-3240-A10R | 16 | 230 | 166 |
| | 32.00 | 32.40 | 3/8" x 10" | FC5-3200-3240-B10R | 16 | 230 | 184 |
| | 32.00 | 32.74 | 1/4" x 10" | FC5-3200-3274-A10R | 16 | 230 | 166 |
| 36" | 36.00 | 38.30 | 1/4" X 10" | FC5-3600-3830-A10R | 18 | 193 | 186 |
| | 37.96 | 38.30 | 1/4" x 10" | FC5-3796-3830-A10R | 18 | 193 | 225 |
| | 38.30 | 38.70 | 1/4" x 10" | FC5-3830-3870-A10R | 18 | 193 | 230 |
| | 38.30 | 38.70 | 3/8" x 10" | FC5-3830-3870-B10R | 18 | 193 | 267 |
| | 38.30 | 38.70 | 3/8" x 15" | FC5-3830-3870-B15R | 18 | 193 | 341 |
| | 38.30 | 39.16 | 1/4" x 10" | FC5-3830-3916-A10R | 18 | 193 | 230 |
| 42" | 44.20 | 44.50 | 3/8" x 10" | FC5-4420-4450-B10R | 20 | 250 | 318 |
| | 44.50 | 45.10 | 3/8" x 10" | FC5-4450-4510-B10R | 20 | 250 | 320 |
| | 44.50 | 45.10 | 3/8" x 15" | FC5-4450-4510-B15R | 20 | 250 | 415 |
| | 44.50 | 45.58 | 3/8" x 10" | FC5-4450-4558-B10R | 20 | 250 | 320 |
| 48" | 50.50 | 50.80 | 3/8" x 10" | FC5-5050-5080-B10R | 22 | 220 | 363 |
| | 50.80 | 51.40 | 3/8" x 10" | FC5-5080-5140-B10R | 22 | 220 | 363 |
| | 50.80 | 51.40 | 3/8" x 15" | FC5-5080-5140-B15R | 22 | 220 | 465 |
| | 50.80 | 51.98 | 3/8" x 10" | FC5-5080-5198-B10R | 22 | 220 | 363 |

Ford Steel Reducing Couplings

Style FC6

Ford Steel Reducing Couplings are designed to connect plain end pipes with an O.D. differential of more than 1". When ordering, use the table shown on the next page or use the exact O.D. measurements of the two plain end pipes to be joined.

Bolts and Nuts - High strength low alloy steel per ASTM A242 and AWWA C111
 Optional: - Type 304 stainless steel
 - Type 316 stainless steel
 - Electro-galvanized steel
 - Blue Fluorocarbon coating

Body Sleeve - ASTM A36 carbon steel

Finish - Black shop coat
 Optional: - Epoxy coating

Gasket - SBR Rubber
 Optional: - Buna-N
 - EPDM

End Rings - 4" - 20" per ASTM A536 ductile iron; 24" - 60" AISI cold rolled or extruded carbon steel (1018-1020)

Rated Working Water Pressure - 150 psi working water pressure for a coupling with a reduction of 2 nominal pipe sizes or less.

For information about high pressure applications or reductions of more than two nominal pipe sizes, please contact your Ford Meter Box Customer Service Representative.

Caution: Reducing couplings do not restrain axial pipe movement. Unbalanced forces created by internal water pressure or external forces must be properly restrained.

How to order FC6 couplings:

Our code system is used to designate the part number. Each code determines how the coupling will be manufactured. Select the large end catalog number and small catalog number from the chart on page 21. Ford will manufacture FC6 couplings to your specifications using the material and dimensional parameters listed below. **Before ordering a special pipe O.D., make sure your O.D. is not in the listed ranges.**

The example shown below is an FC6-1780-1275-R. This coupling is made to fit a 17.80 O.D. pipe and 12.75 O.D. pipe using standard bolts and finished with a standard shop coat.

FC6-1780-1275-R

Product Identification:
Fabricated Steel Reducing Coupling

Large End Pipe O.D.

Small End Pipe O.D.

| COATING, BOLTS AND GASKET OPTIONS | | | | |
|-----------------------------------|-------------------------------|---------------------------|---------------------------|--------------------------|
| GASKET MATERIAL | COATING AND BOLT COMBINATIONS | | | |
| | Standard Alloy Bolts | 304 Stainless Steel Bolts | 316 Stainless Steel Bolts | Electro Galvanized Bolts |
| Standard Shop Coat | | | | |
| SBR Rubber | R | X | Q | G |
| Buna-N Rubber | N | H | J | F |
| EPDM Rubber | S | M | V | W |
| Epoxy Coated | | | | |
| SBR Rubber | E | Y | Z | K |
| Buna-N Rubber | C | P | T | O |
| EPDM Rubber | A | B | D | L |

Note: See item listings in catalog section to assure that desired sizes and options are available

Ford Steel Reducing Couplings

Style FC6

| Large End | | | | | BY | Small End | | | | | |
|----------------|-----------------|--------------------------|-------------------|-----------------|-------------|----------------|-----------------|--------------------------|-------------------|-----------------|---|
| NOM. PIPE SIZE | SMALL END RANGE | SMALL END CATALOG NUMBER | LENGTH OF SM. END | NUMBER OF BOLTS | | NOM. PIPE SIZE | SMALL END RANGE | SMALL END CATALOG NUMBER | LENGTH OF SM. END | NUMBER OF BOLTS | |
| 4" | 4.00 | FC6-400 | 5" | 3 | BY | 2" | 2.30-2.45 | -245-R | 7" | 2 | |
| | 4.50-4.80 | FC6-480 | 5" | 3 | | | 2.40-2.65 | -265-R | 7" | 2 | |
| | 4.80-5.10 | FC6-510 | 5" | 3 | | | 2.65-2.88 | -288-R | 7" | 2 | |
| | 5.15-5.57 | FC6-557 | 5" | 3 | | | 3.45-3.60 | -360-R | 7" | 3 | |
| | 6" | 6.00 | FC6-600 | 5" | | | 4 | 3.70-3.88 | -388-R | 7" | 3 |
| | | 6.63-6.90 | FC6-690 | 5" | | | 4 | 4.07-4.20 | -420-R | 7" | 3 |
| | | 6.90-7.20 | FC6-720 | 5" | | | 4 | 4.00 | -400-R | 7" | 3 |
| | | 7.21-7.56 | FC6-756 | 5" | | | 4 | 4.50-4.80 | -480-R | 7" | 3 |
| | 8" | 8.00 | FC6-800 | 5" | | | 5 | 4.80-5.10 | -510-R | 7" | 3 |
| | | 8.63-9.05 | FC6-905 | 5" | | | 5 | 5.15-5.57 | -557-R | 7" | 3 |
| | | 9.05-9.40 | FC6-940 | 5" | | | 5 | 6.00 | -600-R | 7" | 4 |
| | | 9.40-9.74 | FC6-974 | 5" | | | 5 | 6.63-6.90 | -690-R | 7" | 4 |
| | 10" | 10.00 | FC6-1000 | 5" | | | 6 | 6.90-7.20 | -720-R | 7" | 4 |
| | | 10.75 | FC6-1075 | 5" | | | 6 | 7.21-7.56 | -756-R | 7" | 4 |
| | | 11.10-11.46 | FC6-1146 | 5" | | | 6 | 8.00 | -800-R | 7" | 5 |
| | | 11.42-11.77 | FC6-1177 | 5" | | | 6 | 8.63-9.05 | -905-R | 7" | 5 |
| | 12" | 11.77-12.12 | FC6-1212 | 5" | | | 6 | 9.05-9.40 | -940-R | 7" | 5 |
| | | 12.00 | FC6-1200 | 5" | | | 7 | 9.40-9.74 | -974-R | 7" | 5 |
| | | 12.75 | FC6-1275 | 5" | | | 7 | 10.00 | -1000-R | 5" | 6 |
| | | 13.20-13.56 | FC6-1356 | 5" | | | 7 | 10.75 | -1075-R | 7" | 6 |
| 14"-16" | 13.69-14.04 | FC6-1404 | 5" | 7 | 11.10-11.46 | -1146-R | 7" | 6 | | | |
| | 14.04-14.38 | FC6-1438 | 5" | 7 | 11.42-11.77 | -1177-R | 7" | 6 | | | |
| | 15.30-15.70 | FC6-1570 | 5" | 9 | 11.77-12.12 | -1212-R | 7" | 6 | | | |
| | 16.00-16.35 | FC6-1635 | 5" | 9 | 12.00 | -1200-R | 5" | 7 | | | |
| 16"-18" | 16.40-16.88 | FC6-1688 | 5" | 9 | 12.75 | -1275-R | 7" | 7 | | | |
| | 17.40-17.80 | FC6-1780 | 5" | 10 | 13.20-13.56 | -1356-R | 7" | 7 | | | |
| | 17.85-18.25 | FC6-1825 | 5" | 11 | 13.69-14.04 | -1404-R | 7" | 7 | | | |
| | 18.90-19.20 | FC6-1920 | 5" | 10 | 14.04-14.38 | -1438-R | 7" | 7 | | | |
| 18"-20" | 19.50-20.00 | FC6-2000 | 5" | 11 | 15.30-15.70 | -1570-R | 7" | 9 | | | |
| | 21.60-22.06 | FC6-2206 | 5" | 12 | 16.00-16.35 | -1635-R | 7" | 9 | | | |
| | 24.00 | FC6-2400 | 5" | 14 | 16.40-16.88 | -1688-R | 7" | 9 | | | |
| | 25.80 | FC6-2580 | 5" | 14 | 17.40-17.80 | -1780-R | 7" | 10 | | | |
| 24" | 26.32 | FC6-2632 | 5" | 14 | 17.85-18.25 | -1825-R | 7" | 11 | | | |
| | 30.00 | FC6-3000 | 5" | 16 | 18.90-19.20 | -1920-R | 7" | 10 | | | |
| | 32.00 | FC6-3200 | 5" | 16 | 19.50-20.00 | -2000-R | 7" | 11 | | | |
| | 32.40 | FC6-3240 | 5" | 16 | 21.60-22.06 | -2206-R | 7" | 12 | | | |
| 30" | 36.00 | FC6-3600 | 5" | 18 | 24.00 | -2400-R | 7" | 14 | | | |
| | 38.30 | FC6-3830 | 5" | 18 | 25.80 | -2580-R | 7" | 14 | | | |
| | 42.00 | FC6-4200 | 5" | 20 | 26.32 | -2632-R | 7" | 14 | | | |
| | 44.50 | FC6-4450 | 5" | 20 | 30.00 | -3000-R | 7" | 16 | | | |
| 36" | 48.00 | FC6-4800 | 5" | 22 | 32.00 | -3200-R | 7" | 16 | | | |
| | 49.00 | FC6-4900 | 5" | 22 | 32.40 | -3240-R | 7" | 16 | | | |
| | 50.80 | FC6-5080 | 5" | 22 | 36.00 | -3600-R | 7" | 18 | | | |
| | 55.00 | FC6-5500 | 5" | 24 | 38.30 | -3830-R | 7" | 18 | | | |
| 42" | 56.66 | FC6-5666 | 5" | 24 | 42.00 | -4200-R | 7" | 20 | | | |
| | 57.10 | FC6-5710 | 5" | 24 | 44.50 | -4450-R | 7" | 20 | | | |
| | 57.56 | FC6-5756 | 5" | 24 | 48.00 | -4800-R | 7" | 22 | | | |
| | 57.80 | FC6-5780 | 5" | 24 | 49.00 | -4900-R | 7" | 22 | | | |
| 48" | 60.00 | FC6-6000 | 5" | 26 | 50.80 | -5080-R | 7" | 22 | | | |
| | 61.00 | FC6-6100 | 5" | 26 | 55.00 | -5500-R | 7" | 24 | | | |
| | 61.61 | FC6-6161 | 5" | 26 | 56.66 | -5666-R | 7" | 24 | | | |
| | 63.40 | FC6-6340 | 5" | 26 | 57.10 | -5710-R | 7" | 24 | | | |
| 54" | 63.40 | FC6-6340 | 5" | 26 | 57.56 | -5756-R | 7" | 24 | | | |
| | 60" | 60.00 | FC6-6000 | 5" | 26 | 57.80 | -5780-R | 7" | 24 | | |
| | | 61.00 | FC6-6100 | 5" | 26 | 60.00 | -6000-R | 7" | 26 | | |
| | | 61.61 | FC6-6161 | 5" | 26 | 61.00 | -6100-R | 7" | 26 | | |
| 63.40 | | FC6-6340 | 5" | 26 | 61.61 | -6161-R | 7" | 26 | | | |
| 60" | | | | | 63.40 | -6340-R | 7" | 26 | | | |

Ford Steel Flange Coupling Adapters

Style FCA

Ford Steel Flange Coupling Adapters are used to connect plain end pipe to flanged fittings such as meters or valves. Thrust protection must be provided to prevent the pipe from blowing out of the adapter. Optional restrainers or anchor studs are offered as thrust protection. Fabricated steel flange coupling adapters are normally furnished with flange size matching the nominal pipe size; however, reduced flange sizes are available. For example, a 16" FCA may be ordered with a 12" flange.



Bolts and Nuts - High strength low alloy steel per ASTM A242 and AWWA C111
 Optional: - Type 304 stainless steel
 - Type 316 stainless steel
 - Electro-galvanized steel
 - Blue Fluorocarbon coating

Body Sleeve - ASTM A36 carbon steel

Anchor Studs (Optional) - Cold rolled steel per AISI 1141

Flange - AWWA C207 class D flange.
 Optional: Other AWWA, ISO, DIN or custom flanges are available

End Ring - 4" - 20" per ASTM A536 Ductile iron; 24" - 60" AISI 1018-1020 cold rolled or extruded carbon steel

Gasket - SBR rubber
 Optional: - Buna-N
 - EPDM

Finish - Black shop coat
 Optional: - Epoxy coating

Caution: Flexible couplings do not restrain axial pipe movement. Unbalanced forces created by internal water pressure or external forces must be restrained. Restrained couplings using Uni-Flange restrainers can be found in Catalog Section U. Contact factory for details.

How to order FCA couplings:

Orders may be placed by using catalog numbers from pages 24 and 25, which designate the pipe O.D. and flange size. If the pipe size or desired options are not listed, use the code system detailed below to create the catalog number. Each field of the number is significant in determining exactly how the coupling will be manufactured. The example shown below is an FCA-1780-D12R-AS4. This steel reducing flanged coupling adapter is made to fit a range of pipe sizes from 17.40" to 17.80" and has a 12" AWWA Class D flange. The four anchor studs on this unit will prevent pipe movement up to a maximum operating pressure of 100 psi.

FCA-1780-D12R-AS4

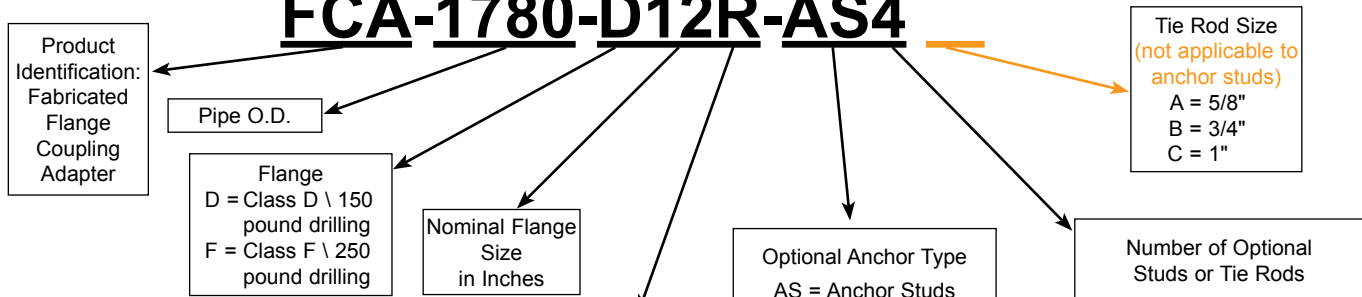

| COATING, BOLTS AND GASKET OPTIONS | | | | |
|-----------------------------------|----------------------|---------------------------|---------------------------|--------------------------|
| COATING AND BOLT COMBINATIONS | | | | |
| GASKET MATERIAL | Standard Alloy Bolts | 304 Stainless Steel Bolts | 316 Stainless Steel Bolts | Electro Galvanized Bolts |
| Standard Shop Coat | | | | |
| SBR Rubber | R | X | Q | G |
| Buna-N Rubber | N | H | J | F |
| EPDM Rubber | S | M | V | W |
| Epoxy Coated | | | | |
| SBR Rubber | E | Y | Z | K |
| Buna-N Rubber | C | P | T | O |
| EPDM Rubber | A | B | D | L |

Note: See item listings in catalog section to assure that desired sizes and options are available

Optional Anchor Type
 AS = Anchor Studs (requires drilling of pipe)
 *R2 = Restrainer Lugs and Harness
 R3 = Restrainer Lugs (field welded to pipe)

Number of Optional Studs or Tie Rods
 A minimum of 2 are required. The total needed is determined by the force to be restrained and the size of the pipe.

Please contact the Ford Customer Service Department for information about anchor studs or other restraint requirements for your specific application.

* Restrainer harness assemblies are manufactured to a specific pipe O.D. **Please include the specific pipe O.D. on order.** See Ford Restrainer Assemblies (page 30) for more information.

Ford Steel Flange Coupling Adapters

Style FCA

Example of Part Number System

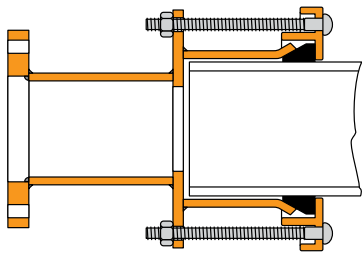

FCA-1146-D8R
Reducing FCA Coupling

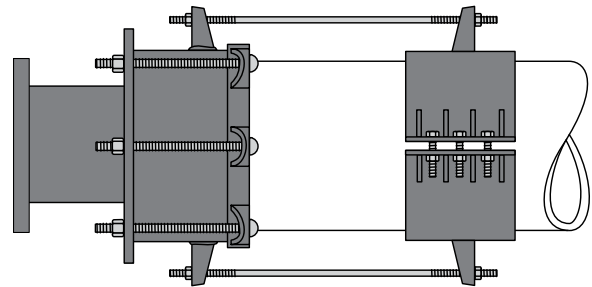

FCA-1110-D8R-R22A
Reducing FCA Coupling with optional
restrainer lug and harness assembly
Note: Exact pipe O.D. is required to ensure
proper harness size.

Dimension Chart

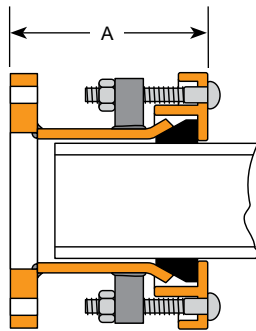

Standard FCA Coupling

| Pipe Size | "A" Dimension |
|-----------|---------------|
| 4" - 6" | 8.5" |
| 8" - 48" | 11.5" |

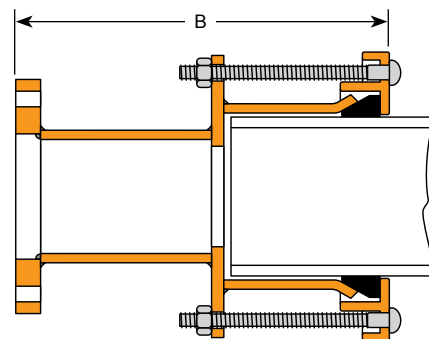

Reducing FCA Coupling

| Pipe Size | "B" Dimension |
|-----------|---------------|
| 4" - 48" | 13.5" |

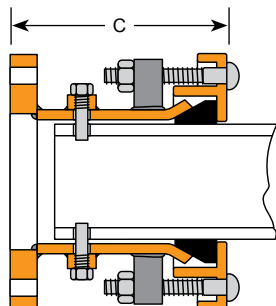

FCA Coupling with (AS)
Optional anchor studs
(for ductile iron or steel pipe,
anchor studs require drilling of pipe)

| Pipe Size | "C" Dimension |
|-----------|---------------|
| 4" - 6" | 11.5" |
| 8" - 48" | 13.5" |

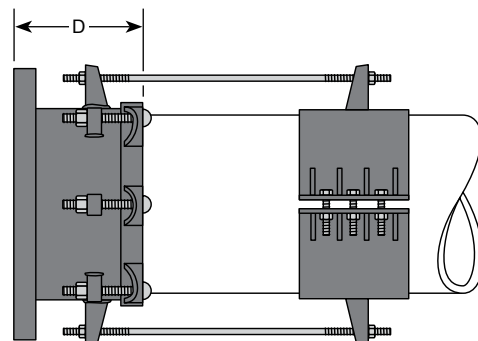

**FCA Coupling with (R2) Optional
Restrainer Lug and Harness Assembly**

| Pipe Size | "D" Dimension |
|-----------|---------------|
| 4" - 6" | 13.5" |
| 8" - 48" | 15.5" |

Ford Steel Flange Coupling Adapters

Style FCA

Listed below are the common sizes of FCA couplings.

If your pipe O.D. is not in the listed ranges, use the code system to *create* your catalog number.
(See page 22). Ductile iron flange coupling adapters are detailed in catalog section M.

| NOM. PIPE SIZE | PIPE O.D. | FLANGE SIZE | RANGE (COUPLING END) | CATALOG NUMBER | RATED WORKING PRESSURE | NUMBER OF END RING BOLTS | APPROX. WT. LBS. |
|----------------|-----------|-------------|----------------------|----------------|------------------------|--------------------------|------------------|
| 4" | 4.00 | 4" | 4.00 | FCA-400-D4R | 175 | 3 | 26 |
| | 4.50 | 4" | 4.50-4.80 | FCA-480-D4R | 175 | 3 | 26 |
| | 4.80 | 4" | 4.50-4.80 | FCA-480-D4R | 175 | 3 | 26 |
| 6" | 6.00 | 4" | 6.00 | FCA-600-D4R | 175 | 4 | 40 |
| | 6.00 | 6" | 6.00 | FCA-600-D6R | 175 | 4 | 36 |
| | 6.63 | 4" | 6.63-6.90 | FCA-690-D4R | 175 | 4 | 40 |
| | 6.63 | 6" | 6.63-6.90 | FCA-690-D6R | 175 | 4 | 36 |
| | 6.90 | 4" | 6.63-6.90 | FCA-690-D4R | 175 | 4 | 40 |
| | 6.90 | 6" | 6.63-6.90 | FCA-690-D6R | 175 | 4 | 36 |
| | 8" | 8.63 | 4" | 8.63-9.05 | FCA-905-D4R | 175 | 5 |
| 8.00 | | 6" | 8.00 | FCA-800-D6R | 175 | 5 | 48 |
| 8.00 | | 8" | 8.00 | FCA-800-D8R | 175 | 5 | 49 |
| 8.63 | | 6" | 8.63-9.05 | FCA-905-D6R | 175 | 5 | 53 |
| 8.63 | | 8" | 8.63-9.05 | FCA-905-D8R | 175 | 5 | 49 |
| 9.05 | | 4" | 8.63-9.05 | FCA-905-D4R | 175 | 5 | 46 |
| 9.05 | | 6" | 8.63-9.05 | FCA-905-D6R | 175 | 5 | 53 |
| 9.05 | | 8" | 8.63-9.05 | FCA-905-D8R | 175 | 5 | 49 |
| 10" | | 10.00 | 8" | 10.00 | FCA-1000-D8R | 175 | 6 |
| | 10.00 | 10" | 10.00 | FCA-1000-D10R | 175 | 6 | 64 |
| | 10.75 | 6" | 10.75 | FCA-1075-D6R | 175 | 6 | 66 |
| | 10.75 | 8" | 10.75 | FCA-1075-D8R | 175 | 6 | 70 |
| | 10.75 | 10" | 10.75 | FCA-1075-D10R | 175 | 6 | 63 |
| | 11.10 | 6" | 11.10-11.46 | FCA-1146-D6R | 175 | 6 | 62 |
| | 11.10 | 8" | 11.10-11.46 | FCA-1146-D8R | 175 | 6 | 71 |
| 12" | 11.10 | 10" | 11.10-11.46 | FCA-1146-D10R | 175 | 6 | 62 |
| | 12.00 | 10" | 12.00 | FCA-1200-D10R | 175 | 7 | 78 |
| | 12.00 | 12" | 12.00 | FCA-1200-D12R | 175 | 7 | 81 |
| | 12.75 | 8" | 12.75 | FCA-1275-D8R | 175 | 7 | 82 |
| | 12.75 | 10" | 12.75 | FCA-1275-D10R | 175 | 7 | 92 |
| | 12.75 | 12" | 12.75 | FCA-1275-D12R | 175 | 7 | 89 |
| | 13.20 | 8" | 13.20-13.56 | FCA-1356-D8R | 175 | 7 | 80 |
| | 13.20 | 10" | 13.20-13.56 | FCA-1356-D10R | 175 | 7 | 91 |
| 14" | 13.20 | 12" | 13.20-13.56 | FCA-1356-D12R | 175 | 7 | 87 |
| | 14.00 | 10" | 13.69-14.04 | FCA-1404-D10R | 175 | 9 | 92 |
| | 14.00 | 12" | 13.69-14.04 | FCA-1404-D12R | 175 | 9 | 114 |
| | 15.30 | 10" | 15.30-15.70 | FCA-1570-D10R | 175 | 9 | 131 |
| | 15.30 | 12" | 15.30-15.70 | FCA-1570-D12R | 175 | 9 | 151 |
| 16" | 15.30 | 14" | 15.30 | FCA-1530-D14R | 150 | 9 | 121 |
| | 16.00 | 12" | 16.00-16.35 | FCA-1635-D12R | 175 | 10 | 152 |
| | 16.00 | 14" | 16.00-16.35 | FCA-1635-D14R | 150 | 10 | 166 |
| | 16.00 | 16" | 16.00 | FCA-1600-D16R | 150 | 10 | 138 |
| | 17.40 | 12" | 17.40-17.80 | FCA-1780-D12R | 175 | 10 | 176 |
| | 17.40 | 14" | 17.40-17.80 | FCA-1780-D14R | 150 | 10 | 170 |
| | 17.40 | 16" | 17.40 | FCA-1740-D16R | 150 | 10 | 144 |
| | 17.80 | 16" | 17.80 | FCA-1780-D16R | 150 | 10 | 145 |

Ford Steel Flange Coupling Adapters

Style FCA

Listed below are the common sizes of FCA couplings.

If your pipe O.D. is not in the listed ranges, use the code system to *create* your catalog number.
(See page 22). Ductile iron flange coupling adapters are detailed in catalog section M.

| NOM. PIPE SIZE | PIPE O.D. | FLANGE SIZE | RANGE (COUPLING END) | CATALOG NUMBER | RATED WORKING PRESSURE | NUMBER OF END RING BOLTS | APPROX. WT. LBS. |
|----------------|-----------|-------------|----------------------|----------------|------------------------|--------------------------|------------------|
| 18" | 18.00 | 14" | 18.00 | FCA-1800-D14R | 150 | 11 | 195 |
| | 18.00 | 16" | 18.00 | FCA-1800-D16R | 150 | 11 | 203 |
| | 18.00 | 18" | 18.00 | FCA-1800-D18R | 150 | 11 | 151 |
| | 19.50 | 14" | 19.50-20.00 | FCA-2000-D14R | 150 | 11 | 194 |
| | 19.50 | 16" | 19.50-20.00 | FCA-2000-D16R | 150 | 11 | 210 |
| 20" | 19.50 | 18" | 19.50 | FCA-1950-D18R | 150 | 11 | 154 |
| | 20.00 | 16" | 19.50-20.00 | FCA-2000-D16R | 150 | 11 | 210 |
| | 20.00 | 18" | 19.50-20.00 | FCA-2000-D18R | 150 | 11 | 194 |
| | 20.00 | 20" | 20.00 | FCA-2000-D20R | 150 | 12 | 175 |
| | 21.60 | 16" | 21.60-22.06 | FCA-2206-D16R | 150 | 12 | 202 |
| | 21.60 | 18" | 21.60-22.06 | FCA-2206-D18R | 150 | 12 | 195 |
| 24" | 21.60 | 20" | 21.60 | FCA-2160-D20R | 150 | 12 | 180 |
| | 22.06 | 24" | 22.06 | FCA-2206-D20R | 150 | 12 | 180 |
| | 24.00 | 18" | 24.00 | FCA-2400-D18R | 150 | 14 | 369 |
| | 24.00 | 20" | 24.00 | FCA-2400-D20R | 150 | 14 | 300 |
| | 24.00 | 24" | 24.00 | FCA-2400-D24R | 150 | 14 | 226 |
| | 25.80 | 18" | 25.80 | FCA-2580-D18R | 150 | 14 | 278 |
| | 25.80 | 20" | 25.80 | FCA-2580-D20R | 150 | 14 | 250 |
| 30" | 25.80 | 24" | 25.80 | FCA-2580-D24R | 150 | 14 | 233 |
| | 30.00 | 20" | 30.00 | FCA-3000-D20R | 150 | 16 | 320 |
| | 30.00 | 24" | 30.00 | FCA-3000-D24R | 150 | 16 | 376 |
| | 30.00 | 30" | 30.00 | FCA-3000-D30R | 150 | 16 | 314 |
| | 32.00 | 20" | 32.00 | FCA-3200-D20R | 150 | 16 | 323 |
| | 32.00 | 24" | 32.00 | FCA-3200-D24R | 150 | 16 | 323 |
| 36" | 32.00 | 30" | 32.00 | FCA-3200-D30R | 150 | 16 | 323 |
| | 36.00 | 24" | 36.00 | FCA-3600-D24R | 150 | 18 | 400 |
| | 36.00 | 30" | 36.00 | FCA-3600-D30R | 150 | 18 | 435 |
| | 36.00 | 36" | 36.00 | FCA-3600-D36R | 150 | 18 | 472 |
| | 38.30 | 24" | 38.30 | FCA-3830-D24R | 150 | 18 | 439 |
| | 38.30 | 30" | 38.30 | FCA-3830-D30R | 150 | 18 | 420 |
| 42" | 38.30 | 36" | 38.30 | FCA-3830-D36R | 150 | 18 | 411 |
| | 42.00 | 30" | 42.00 | FCA-4200-D30R | 150 | 20 | 550 |
| | 42.00 | 36" | 42.00 | FCA-4200-D36R | 150 | 20 | 600 |
| | 42.00 | 42" | 42.00 | FCA-4200-D42R | 150 | 20 | 628 |
| | 44.50 | 30" | 44.50 | FCA-4450-D30R | 150 | 20 | 600 |
| | 44.50 | 36" | 44.50 | FCA-4450-D36R | 150 | 20 | 630 |
| 48" | 44.50 | 42" | 44.50 | FCA-4450-D42R | 150 | 20 | 658 |
| | 48.00 | 36" | 48.00 | FCA-4800-D36R | 150 | 24 | 700 |
| | 48.00 | 42" | 48.00 | FCA-4800-D42R | 150 | 24 | 750 |
| | 48.00 | 48" | 48.00 | FCA-4800-D48R | 150 | 24 | 768 |
| | 50.80 | 36" | 50.80 | FCA-5080-D36R | 150 | 24 | 700 |
| | 50.80 | 42" | 50.80 | FCA-5080-D42R | 150 | 24 | 750 |
| | 50.80 | 48" | 50.80 | FCA-5080-D48R | 150 | 24 | 766 |

Ford Dismantling Joint

Style FDJ

Ford Dismantling Joints are flanged joint fittings that provide longitudinal adjustment in a flanged piping system. This allows for flexibility during design and installation as well as easy accessibility for maintenance.

Style B

Style A

Flanges - ASTM A36 carbon steel, AWWA C207 Class D
Other flanges available upon request

Body and End Ring (Style A) - Ductile iron per ASTM A536 65-45-12

End Ring - Cold rolled or extruded carbon steel per ANSI 1018-1020

Gaskets - SBR extruded or molded rubber per ASTM D2000

Body and Adjusting Pipe - ASTM A36 carbon steel

Boles and Nuts - High strength, low alloy steel per AWWA C111
Optional: - Blue Fluorocarbon coating

Tie Rods are optional. High strength, low alloy steel per AWWA C111.
Optional: Blue Fluorocarbon coating

Finish - Black shop coat
Optional: - Epoxy coating

150 psi rated working water pressure. Higher pressure ratings available. Please contact factory.
Unbalanced forces created by internal water pressure or external forces must be restrained.

Dismantling Joints Less Tie Rods

| NOMINAL SIZE | CATALOG NUMBER | STYLE | NOMINAL LENGTH | MINIMUM LENGTH | MAXIMUM LENGTH | APPROX. WEIGHT LBS. |
|--------------|----------------|-------|----------------|----------------|----------------|---------------------|
| 4" | FDJ-D4R | A | 8-1/8" | 7-1/8" | 9-1/8" | 36 |
| 6" | FDJ-D6R | A | 9-5/16" | 8-1/8" | 10-1/2" | 52 |
| 8" | FDJ-D8R | A | 9-5/16" | 8-1/8" | 10-1/2" | 75 |
| 10" | FDJ-D10R | A | 10-3/4" | 10" | 11-1/2" | 90 |
| 12" | FDJ-D12R | A | 10-3/4" | 10" | 11-1/2" | 127 |
| 14" | FDJ-D14R | B | 13-11/16" | 11-3/4" | 15-5/8" | 280 |
| 16" | FDJ-D16R | B | 14-1/8" | 12-1/8" | 16-1/8" | 295 |
| 18" | FDJ-D18R | B | 13-15/16" | 11-7/8" | 16" | 305 |
| 20" | FDJ-D20R | B | 14-7/8" | 13-5/8" | 16-1/8" | 315 |
| 24" | FDJ-D24R | B | 15-3/16" | 13-3/4" | 16-5/8" | 645 |
| 30" | FDJ-D30R | B | 14-1/8" | 11-5/8" | 16-5/8" | 945 |
| 36" | FDJ-D36R | B | 15-3/16" | 13-3/4" | 16-5/8" | 963 |

Dismantling Joints with Tie Rods

| NOMINAL SIZE | CATALOG NUMBER | STYLE | NOMINAL LENGTH | MINIMUM LENGTH | MAXIMUM LENGTH | TIE RODS | | APPROX. WEIGHT LBS. |
|--------------|----------------|-------|----------------|----------------|----------------|----------|------------|---------------------|
| | | | | | | NUMBER | SIZE | |
| 4" | FDJ-D4R-R | A | 8-1/8" | 7-1/8" | 9-1/8" | 2 | 5/8"x14" | 38 |
| 6" | FDJ-D6R-R | A | 9-5/16" | 8-1/8" | 10-1/2" | 2 | 3/4"x15" | 55 |
| 8" | FDJ-D8R-R | A | 9-5/16" | 8-1/8" | 10-1/2" | 2 | 3/4"x15" | 78 |
| 10" | FDJ-D10R-R | A | 10-3/4" | 10" | 11-1/2" | 2 | 7/8"x17" | 93 |
| 12" | FDJ-D12R-R | A | 10-3/4" | 10" | 11-1/2" | 2 | 7/8"x17" | 130 |
| 14" | FDJ-D14R-R | B | 13-11/16" | 11-3/4" | 15-5/8" | 4 | 1"x24" | 285 |
| 16" | FDJ-D16R-R | B | 14-1/8" | 12-1/8" | 16-1/8" | 4 | 1"x24" | 300 |
| 18" | FDJ-D18R-R | B | 13-15/16" | 11-7/8" | 16" | 4 | 1-1/8"x24" | 310 |
| 20" | FDJ-D20R-R | B | 14-7/8" | 13-5/8" | 16-1/8" | 4 | 1-1/8"x24" | 320 |
| 24" | FDJ-D24R-R | B | 15-3/16" | 13-3/4" | 16-5/8" | 4 | 1-1/4"x24" | 650 |
| 30" | FDJ-D30R-R | B | 14-1/8" | 11-5/8" | 16-5/8" | 7 | 1-1/4"x24" | 955 |
| 36" | FDJ-D36R-R | B | 15-3/16" | 13-3/4" | 16-5/8" | 8 | 1-1/2"x24" | 975 |

Ford Steel Expansion Joints

Style FEJ

Ford Expansion Joint Couplings (FEJ) are specified for piping projects to allow for thermal expansion and contraction. The amount of movement is a factor of the pipe material, the pipeline length, and the temperature differential. The chart on page 29 shows linear pipe expansion of commonly used water pipe.

The Single Expansion Joint Coupling (FEJ1) features **10" of overall pipe movement** with limit rods that transfer pipe movement to any additional expansion joints. The slip pipe is nickel chrome plated to provide a non-abrasive surface to prevent damage to the packing glands. The friction of the packing glands on the slip pipe may be field adjusted using the packing adjusting nuts. Pipe movement may be controlled in both directions unless the Expansion Joint is anchored to a supporting structure. The expansion joint is available with either flanged ends or plain ends, beveled for field welding.

Single Expansion Joint - FEJ1 (with flanged ends)



FEJ1-863-F

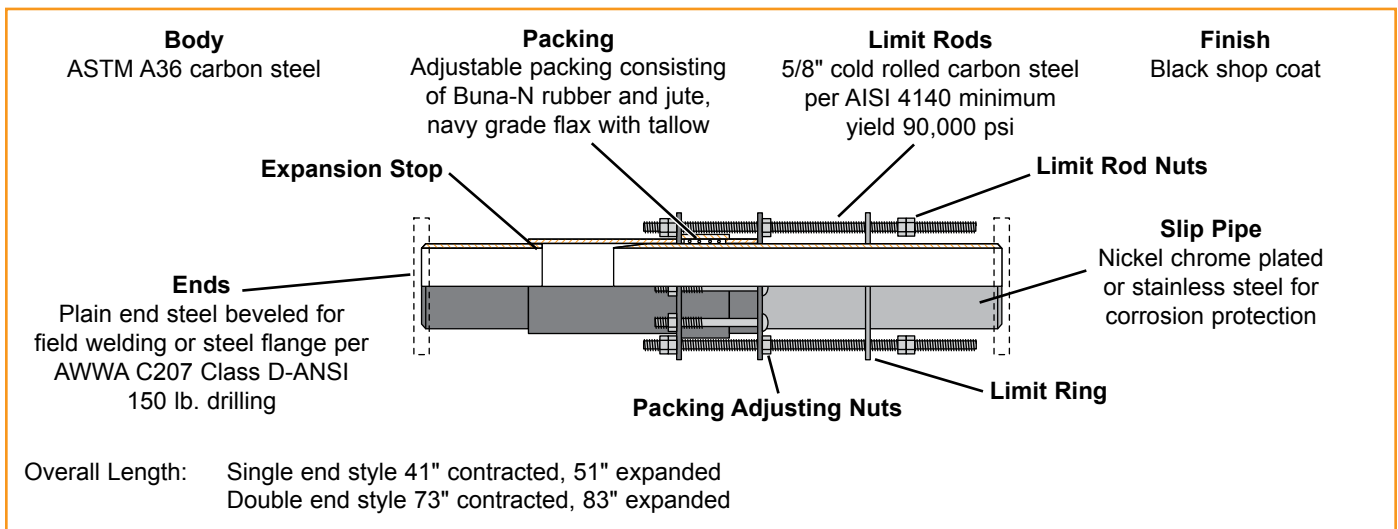

The Double Expansion Joint Coupling (FEJ2) also features two nickel chrome plated slip pipes and adjustable packing glands. The Double Style Expansion Coupling should be permanently attached to a supporting structure in the middle of the sleeve to force equal pipe movement of 5" in both directions. The expansion joint is available with either flanged ends or plain ends, beveled for field welding.

Double Expansion - FEJ2 (with plain ends)

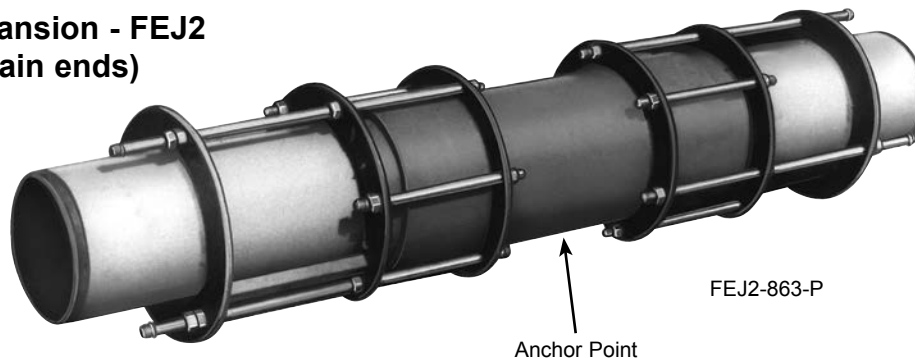

FEJ2-863-P

Anchor Point

Ford Steel Expansion Joints

Style FEJ

Listed below are common sizes of FEJ couplings.

| NOM. PIPE SIZE | PIPE O.D. | NO. OF PACKING CHAMBERS | TYPE OF END CONNECTION | CATALOG NUMBER | RATED WORKING PRESSURE | APPROX. WT. LBS. |
|----------------|-----------|-------------------------|------------------------|----------------|------------------------|------------------|
| 4" | 4.50 | 1 | Plain | FEJ1-450-P | 150 | 97 |
| | | 2 | Plain | FEJ2-450-P | 150 | 148 |
| | | 1 | Flanged | FEJ1-450-F | 150 | 114 |
| | | 2 | Flanged | FEJ2-450-F | 150 | 165 |
| 6" | 6.63 | 1 | Plain | FEJ1-663-P | 150 | 139 |
| | | 2 | Plain | FEJ2-663-P | 150 | 310 |
| | | 1 | Flanged | FEJ1-663-F | 150 | 160 |
| | | 2 | Flanged | FEJ2-663-F | 150 | 331 |
| 8" | 8.63 | 1 | Plain | FEJ1-863-P | 150 | 214 |
| | | 2 | Plain | FEJ2-863-P | 150 | 340 |
| | | 1 | Flanged | FEJ1-863-F | 150 | 244 |
| | | 2 | Flanged | FEJ2-863-F | 150 | 370 |
| 10" | 10.75 | 1 | Plain | FEJ1-1075-P | 150 | 244 |
| | | 2 | Plain | FEJ2-1075-P | 150 | 447 |
| | | 1 | Flanged | FEJ1-1075-F | 150 | 283 |
| | | 2 | Flanged | FEJ2-1075-F | 150 | 487 |
| 12" | 12.75 | 1 | Plain | FEJ1-1275-P | 150 | 299 |
| | | 2 | Plain | FEJ2-1275-P | 150 | 551 |
| | | 1 | Flanged | FEJ1-1275-F | 150 | 366 |
| | | 2 | Flanged | FEJ2-1275-F | 150 | 618 |
| 14" | 14.00 | 1 | Plain | FEJ1-1400-P | 150 | 338 |
| | | 2 | Plain | FEJ2-1400-P | 150 | 514 |
| | | 1 | Flanged | FEJ1-1400-F | 150 | 426 |
| | | 2 | Flanged | FEJ2-1400-F | 150 | 602 |
| 16" | 16.00 | 1 | Plain | FEJ1-1600-P | 150 | 389 |
| | | 2 | Plain | FEJ2-1600-P | 150 | 587 |
| | | 1 | Flanged | FEJ1-1600-F | 150 | 513 |
| | | 2 | Flanged | FEJ2-1600-F | 150 | 711 |
| 18" | 18.00 | 1 | Plain | FEJ1-1800-P | 125 | 426 |
| | | 2 | Plain | FEJ2-1800-P | 125 | 662 |
| | | 1 | Flanged | FEJ1-1800-F | 125 | 552 |
| | | 2 | Flanged | FEJ2-1800-F | 125 | 788 |
| 20" | 20.00 | 1 | Plain | FEJ1-2000-P | 110 | 497 |
| | | 2 | Plain | FEJ2-2000-P | 110 | 738 |
| | | 1 | Flanged | FEJ1-2000-F | 110 | 655 |
| | | 2 | Flanged | FEJ2-2000-F | 110 | 895 |
| 24" | 24.00 | 1 | Plain | FEJ1-2400-P | 100 | 607 |
| | | 2 | Plain | FEJ2-2400-P | 100 | 887 |
| | | 1 | Flanged | FEJ1-2400-F | 100 | 843 |
| | | 2 | Flanged | FEJ2-2400-F | 100 | 1103 |

Ford Steel Expansion Joints

Style FEJ

Ford FEJ Expansion Joint Couplings are specified for piping projects to allow for thermal expansion and contraction of pipe. Actual pipe movement is a result of changes in the ambient temperature, changes to the line content, and/or movement of the pipe supporting structures. The amount of movement is a factor of the pipe material, the pipeline length, and the temperature differential. The number of expansion joints required on each project is determined by the total pipe expansion. Each expansion joint controls 10" of pipe movement. The following chart shows linear pipe expansion of commonly used water pipe.

LINEAR EXPANSION OF PIPE

| TEMPERATURE DIFFERENTIAL DEGREES FAHRENHEIT | INCREASE IN INCHES PER 100 FEET OF PIPE FROM 0 TO TEMPERATURE INDICATED | | | |
|---|---|-----------|--------------|----------------|
| | STEEL | CAST IRON | WROUGHT IRON | BRASS & COPPER |
| 0 | 0.000 | 0.000 | 0.000 | 0.000 |
| 10 | 0.076 | 0.072 | 0.079 | 0.114 |
| 20 | 0.152 | 0.144 | 0.158 | 0.228 |
| 30 | 0.228 | 0.126 | 0.237 | 0.342 |
| 40 | 0.304 | 0.288 | 0.316 | 0.456 |
| 50 | 0.380 | 0.360 | 0.395 | 0.570 |
| 60 | 0.465 | 0.432 | 0.474 | 0.684 |
| 70 | 0.532 | 0.504 | 0.553 | 0.798 |
| 80 | 0.608 | 0.576 | 0.632 | 0.912 |
| 90 | 0.684 | 0.648 | 0.711 | 1.026 |
| 100 | 0.76 | 0.744 | 0.79 | 1.14 |
| 125 | 0.92 | 0.88 | 0.97 | 1.40 |
| 150 | 1.15 | 1.10 | 1.21 | 1.75 |
| 175 | 1.34 | 1.28 | 1.41 | 2.04 |
| 200 | 1.57 | 1.50 | 1.65 | 2.38 |
| 225 | 1.78 | 1.70 | 1.87 | 2.70 |
| 250 | 1.99 | 1.90 | 2.09 | 3.02 |
| 275 | 2.26 | 2.15 | 2.36 | 3.42 |
| 300 | 2.47 | 2.35 | 2.58 | 3.74 |

To calculate total pipe movement: 1. Determine the temperature range in your geographic area, 2. Cross reference with the appropriate pipe material from the above table. **Note:** This figure is based on 100 feet of pipe. Total pipe expansion must take into account the entire length of pipe.

Installation Instructions for Ford Steel Expansion Joints

Ford Expansion Joints are shipped in the fully closed position and must be adjusted to meet field temperature conditions during installation. To adjust, follow these instructions:

SINGLE END STYLE EXPANSION JOINT

1. Calculate the initial installation setting by solving the formula below.

$$\frac{\text{MAXIMUM TEMPERATURE} - \text{INSTALLATION TEMPERATURE}}{\text{MAXIMUM TEMPERATURE} - \text{MINIMUM TEMPERATURE}} \times 10 = \text{INITIAL SETTING IN INCHES}$$

2. Move limit rod nuts to initial setting as calculated in step 1 by measuring from closed position. Expand joint to this position. Attach both expansion joint ends to main line pipe.
3. Make final adjustments by positioning limit rod nuts as follows:

$$\text{TOTAL JOINT RANGE EXPANSION (NORMALLY 10)} - \text{INITIAL SETTING} = \text{LIMIT ROD NUT DISTANCE FROM LIMIT RING}$$
4. Apply water pressure and test for leaks. If leaks appear around slip pipe, tighten packing gland nuts evenly until leak stops.

Ford Restrainer Assemblies

Style FR

Ford Restrainers (FR Style) are designed to prevent pipe movement caused by expansion and contraction, pressure surges, water hammer, and unstable ground conditions. The FR1 Harness-style Restrainer Assembly is suitable for pipe that cannot be easily welded in the field. The clamping force provided by the harness is evenly distributed along the surface of the pipe to prevent damage. All harness assemblies are manufactured for an exact pipe O.D.

The harness to lug restrainer assembly, style FR2, requires field welding of the lugs to steel pipe. This is normally done after the harness assembly is installed, in order to assure proper alignment for the tie rods. The FR3 lug-to-lug style restrainer assembly is used to restrain steel pipe to pipe or to fittings such as a flanged coupling adapter.

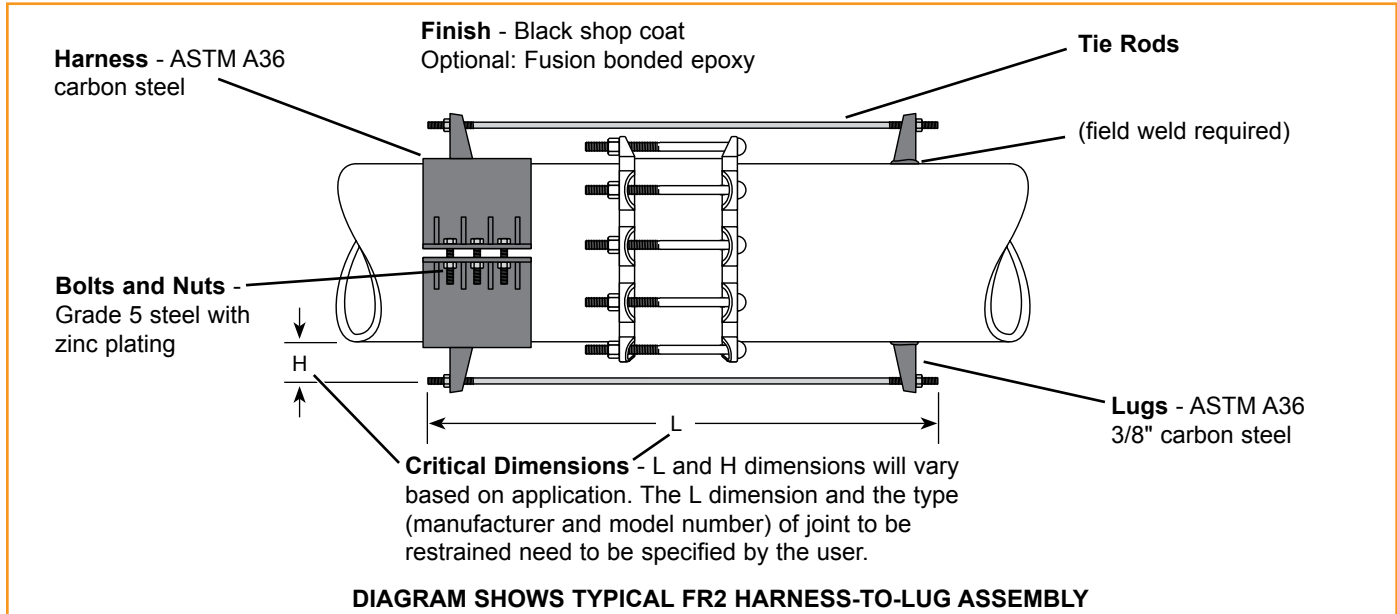

How to order FR Restrainer

Select from page 31 the style assembly most suitable for your application. Note working pressure, pipe O.D., pipe type and all critical dimensions (see drawing above) required for installation. Dimension information is critical to ensure the tie rods will clear pipe joints or any other fitting involved.

Our code system is used to designate the part number. Each code determines how the assembly will be manufactured. Ford will manufacture FR Restrainer assemblies to your specifications. The example shown below is a FR1-663P-690D-2A. This is a harness assembly made to restrain a 6.63 O.D. plastic pipe to a 6.90 O.D. ductile iron pipe and uses two, 5/8" tie rods. All restrainer assemblies are individually quoted.

FR1-663 P-690 D-2 A

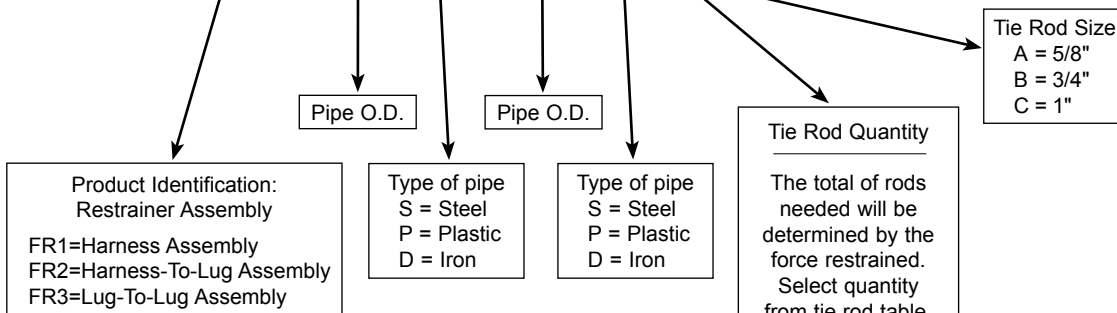

Tie Rod Table
Size and Quantity
for 150 PSI rated
working pressure

| NOM PIPE SIZE | QTY. | ROD SIZE |
|---------------|------|----------|
| 4 | 2 | 5/8" |
| 6 | 2 | 5/8" |
| 8 | 2 | 5/8" |
| 10 | 2 | 3/4" |
| 12 | 4 | 5/8" |
| 14 | 4 | 3/4" |
| 16 | 6 | 3/4" |

Be sure to check the Uni-Flange Catalog and Price Book for additional information and options for restraining PVC and ductile iron pipe joints. Contact Ford for technical support as well as for pricing and availability information regarding restrainer assemblies.

Ford Restrainer Assemblies

Style FR

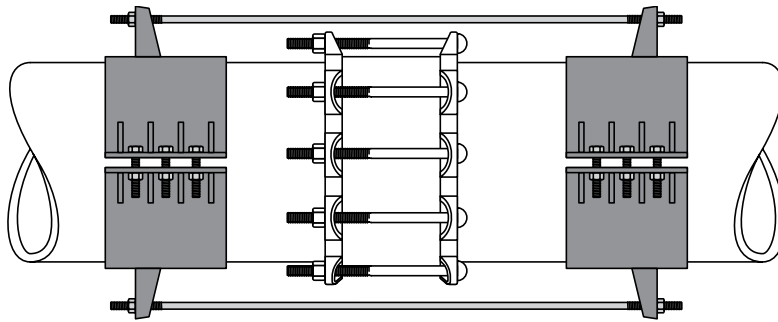

FR1 - Harness Style Restrainer Assembly

Saddle to saddle assembly for use on steel, PVC, cast iron or ductile iron pipe.

A complete assembly includes 2 harnesses and a minimum of 2 tie rods.

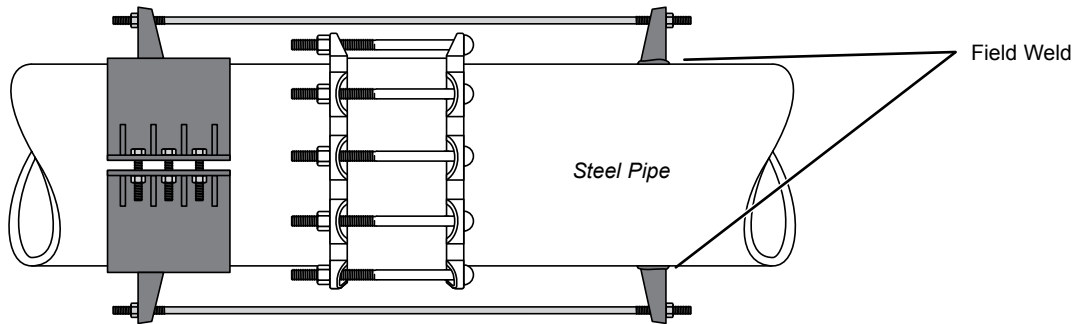

FR2 - Harness-To-Lug Style Restrainer Assembly

Harness to lug assembly for use on steel pipe

A complete assembly includes 1 harness, and a minimum of 2 lugs and 2 tie rods.

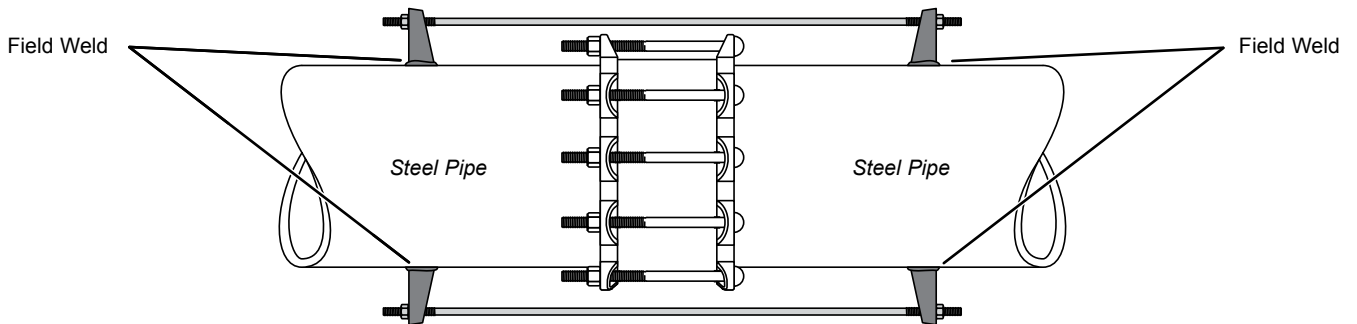

FR3 - Lug-To-Lug Style Restrainer Assembly

Lug to lug assembly for use on steel pipe or steel fittings such as a steel flange coupling adapter.

A complete assembly includes a minimum of 4 lugs and 2 tie rods.

Ford Steel Weld-On Tapping Sleeves

Style FWS

The Ford Weld-on Tapping Sleeve is designed for field welding to steel pipe. The saddle, sized to fit the pipe, has rounded corners to allow a continuous weld. The welding surface is not painted. The standard steel flange conforms to AWWA C207 Class D ANSI 150 drilling and all sleeves are furnished with a 3/4" test port. Please note that sleeves with outlet sizes through 12" require the use of a shell cutter 1/2" smaller than the nominal flange size. Larger sizes require a shell cutter 1" smaller than the flange size.

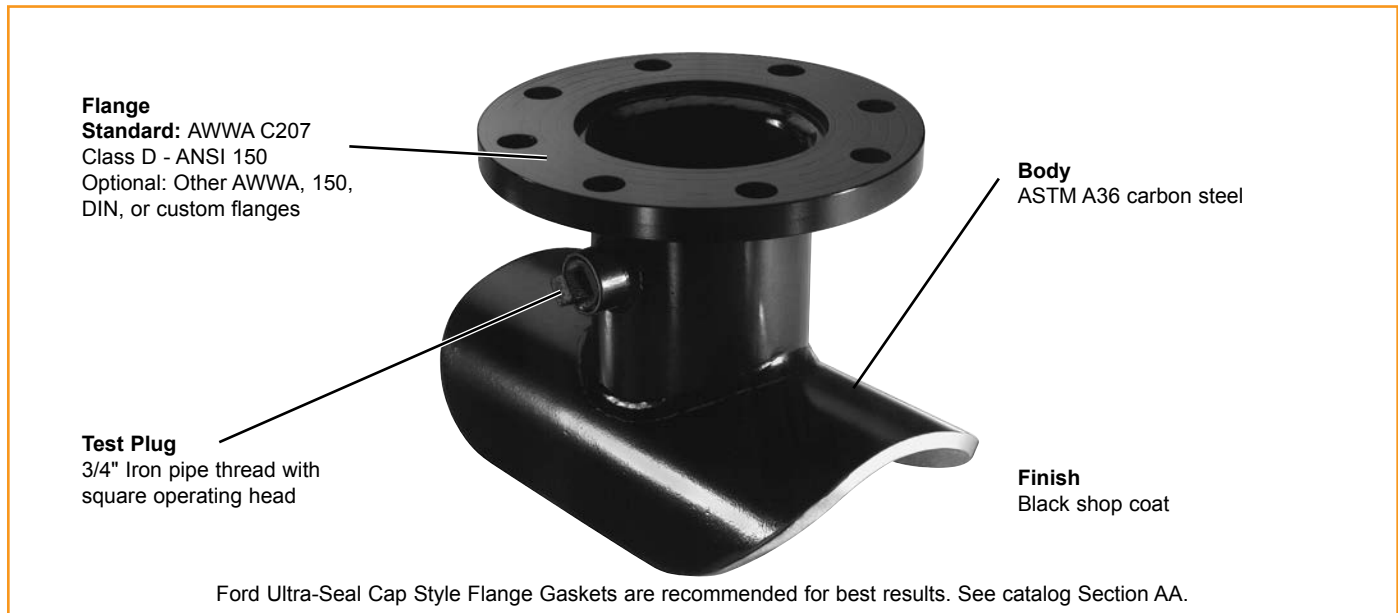

Style FWS Weld-On Tapping Sleeves

| NOM PIPE SIZE | PIPE O.D. | FLANGE SIZE | CATALOG NUMBER | PRESSURE RATING |
|---------------|-----------|-------------|----------------|-----------------|
| 3" | 3.50 | 3" | FWS-350-3 | 175 |
| | 4.00 | 3" | FWS-400-3 | 175 |
| 4" | | 4.50 | 4" | FWS-400-4 |
| | 3" | | FWS-450-3 | 175 |
| | 6.00 | 4" | FWS-450-4 | 175 |
| | | 4" | FWS-600-4 | 175 |
| 6" | 6.63 | 6" | FWS-600-6 | 175 |
| | | 4" | FWS-663-4 | 175 |
| | 8.00 | 6" | FWS-663-6 | 175 |
| | | 4" | FWS-800-4 | 175 |
| 8" | 8.63 | 6" | FWS-800-6 | 175 |
| | | 8" | FWS-800-8 | 175 |
| | | 4" | FWS-863-4 | 175 |
| | 10.00 | 6" | FWS-863-6 | 175 |
| | | 8" | FWS-863-8 | 175 |
| | | 6" | FWS-1000-6 | 175 |
| 10" | 10.75 | 8" | FWS-1000-8 | 175 |
| | | 10" | FWS-1000-10 | 175 |
| | | 4" | FWS-1075-4 | 175 |
| | 12.00 | 6" | FWS-1075-6 | 175 |
| | | 8" | FWS-1075-8 | 175 |
| | | 10" | FWS-1075-10 | 175 |
| 12" | 12.75 | 8" | FWS-1200-8 | 175 |
| | | 10" | FWS-1200-10 | 175 |
| | | 12" | FWS-1200-12 | 175 |
| | 12.75 | 4" | FWS-1275-4 | 175 |
| | | 6" | FWS-1275-6 | 175 |
| | | 8" | FWS-1275-8 | 175 |
| 12.75 | 10" | FWS-1275-10 | 175 | |
| | 12" | FWS-1275-12 | 175 | |

Larger sizes available. Please contact factory for more information. See catalog section AA for bolt-on style tapping sleeves.

Ford Miscellaneous Steel Fittings

The following fittings are commonly used for plant installation and can be modified for specialized requirements. Use the drawings below as a reference when requesting a quotation. All fabricated steel fittings will conform to dimensions tables in AWWA C208.

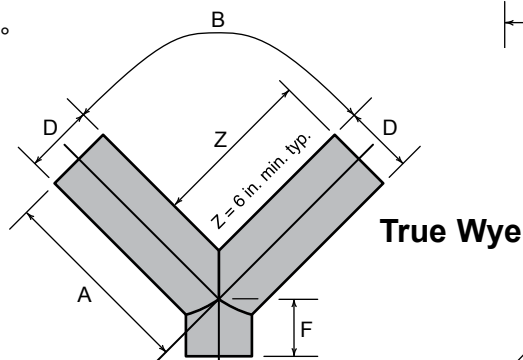
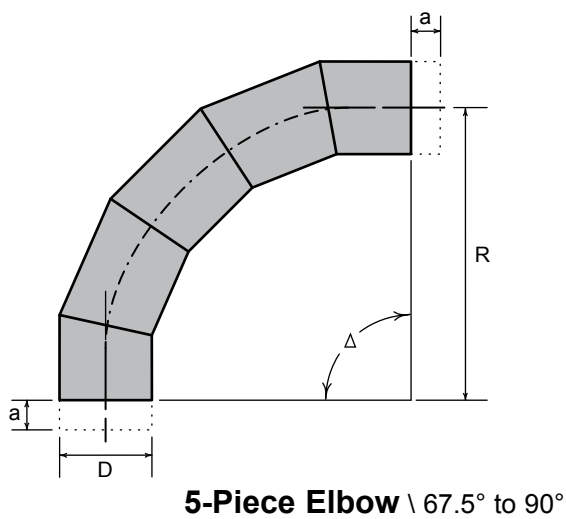
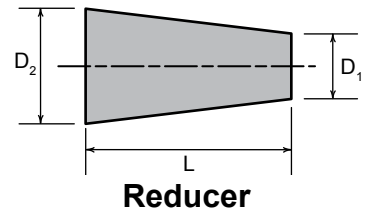
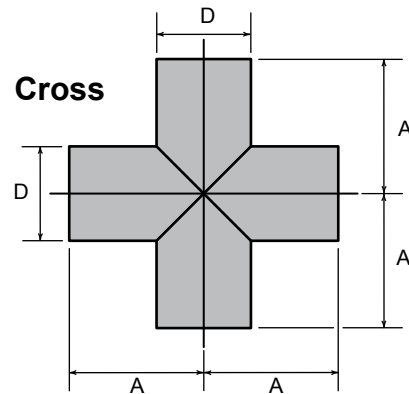
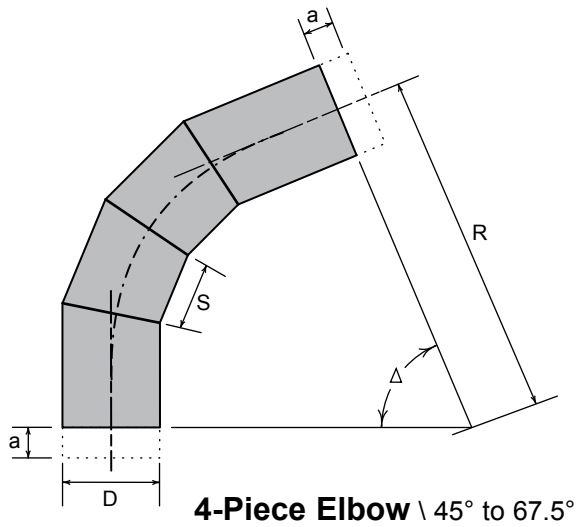
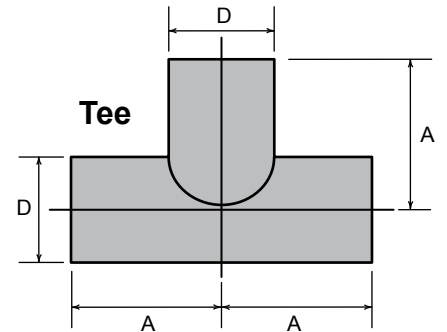
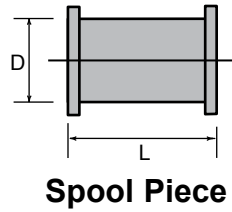
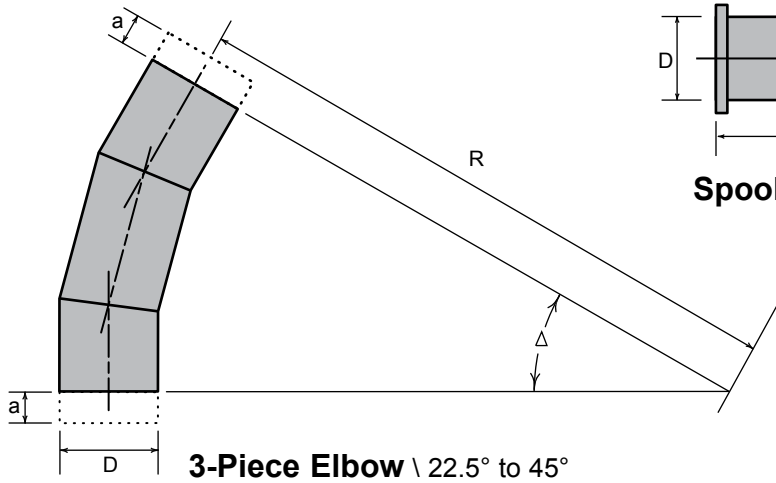

Lateral
45° min; 75° max

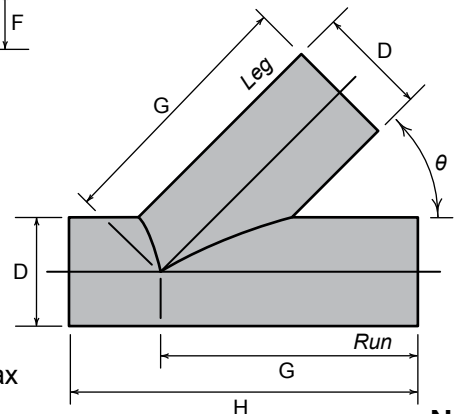

Stainless Steel Inserts

For HDPE Pipe

Ford stainless steel inserts prevent HDPE pipe from losing rigidity on the end while also keeping the gasket or restraint functioning properly on the pipe. With one end tapered and a lip on the other, the solid design is easy to install and can't be over-inserted.



Features:

- Solid design on 6" and larger sizes (3" and 4" are wedge design)
- 18 GA Type 304 stainless steel per ASTM A240 (with optional 316 stainless steel)
- Chemically passivated to restore natural corrosion-resistant state
- Durable, ergonomic design allows for a simple installation and long-lasting life

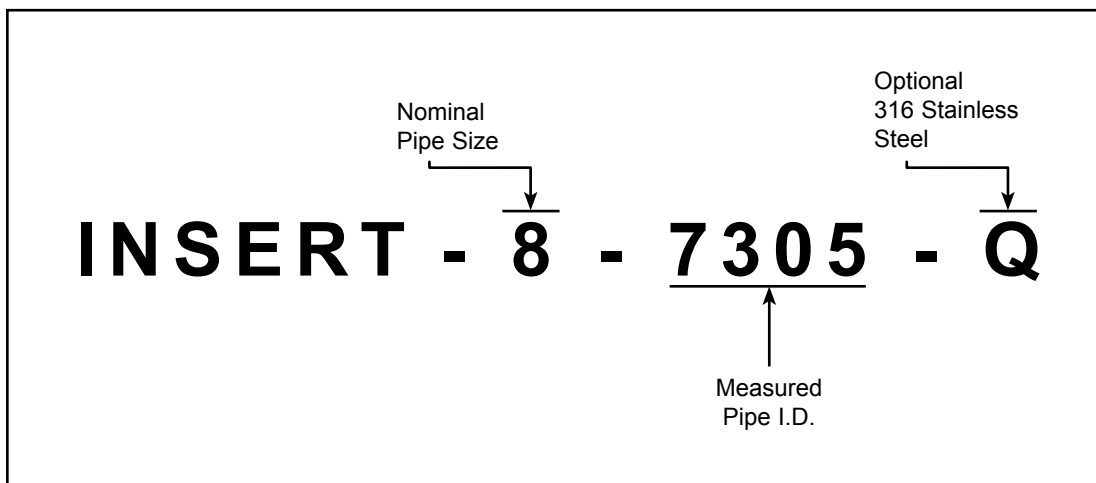

| NOM. PIPE SIZE | *CATALOG NUMBER | LENGTH | APPROX. WT. LBS. |
|----------------|-----------------|--------|------------------|
| 3" | INSERT-3-xxx | 6" | 1.2 |
| 4" | INSERT-4-xxx | | 1.5 |
| 6" | INSERT-6-xxx | 7-3/8" | 2.1 |
| 8" | INSERT-8-xxx | | 2.8 |
| 10" | INSERT-10-xxxx | | 3.5 |
| 12" | INSERT-12-xxxx | | 4.1 |
| 14" | INSERT-14-xxxx | | 4.8 |
| 16" | INSERT-16-xxxx | | 5.5 |
| 18" | INSERT-18-xxxx | | 6.1 |
| 20" | INSERT-20-xxxx | | 6.8 |
| 24" | INSERT-24-xxxx | | 8.1 |
| 30" | INSERT-30-xxxx | | 10.1 |
| 36" | INSERT-36-xxxx | 11.5 | |

*When ordering, the pipe inside diameter is required. For example, when ordering for an 8" pipe with an I.D. of 7.305", the part number is INSERT-8-7305.

O.D. Chart

| PIPE SIZE | PVC/HDPE (Steel Size) O.D. | PVC/HDPE C900/C905 O.D. | DUCTILE / CAST IRON | | | ASBESTOS-CEMENT | | | STEEL | | COPPER |
|-----------|----------------------------|-------------------------|---------------------|-----------|-------|-----------------|-------------------|-----------------------------|-------|-------|--------|
| | | | Classes | | O.D. | Class | Machined End O.D. | Rough Barrel O.D. Min - Max | Type | O.D. | O.D. |
| | | | Pit | Spun | | | | | | | |
| 1/2" | .84 | | | | | | | | STD. | .84 | .625 |
| 3/4" | 1.05 | | | | | | | | STD. | 1.05 | .875 |
| 1" | 1.32 | | | | | | | | STD. | 1.32 | 1.125 |
| 1-1/4" | 1.66 | | | | | | | | STD. | 1.66 | 1.375 |
| 1-1/2" | 1.90 | | | | | | | | STD. | 1.90 | 1.625 |
| 2" | 2.38 | | | | 2.50 | | | | STD. | 2.38 | 2.125 |
| 2-1/2" | 2.88 | | | | | | | | STD. | 2.88 | 2.625 |
| 3" | 3.50 | | A | | 3.80 | 100 | 3.74 | 4.00 | O.D. | 3.00 | 3.125 |
| | | | B, C, D | 50 - 350 | 3.96 | 150 | 3.84 | 4.10 | STD. | 3.50 | |
| | | | | | | 200 | 3.84 | 4.29 | | | |
| 3-1/2" | | | | | | | | STD. | 4.00 | 3.625 | |
| 4" | 4.50 | 4.80 | A | 50 - 350 | 4.80 | 100 | 4.64 | 4.79 - 5.14 | O.D. | 4.00 | 4.125 |
| | | | B, C, D | | 5.00 | 150 | 4.81 | 4.97 - 5.27 | STD. | 4.50 | |
| | | | | | | 200 | 4.81 | 5.22 - 5.57 | | | |
| 4-1/2" | | | | | | | | STD. | 5.00 | | |
| 5" | | | | | | | | STD. | 5.56 | 5.125 | |
| 6" | 6.63 | 6.90 | A | 50 - 350 | 6.90 | 100 | 6.91 | 7.05 - 7.40 | O.D. | 6.00 | 6.125 |
| | | | B, C, D, | | 7.10 | 150 | 6.91 | 7.07 - 7.37 | STD. | 6.63 | |
| | | | E, F | | 7.22 | 200 | 6.91 | 7.26 - 7.56 | | | |
| 7" | | | | | | | | STD. | 7.63 | | |
| 8" | 8.63 | 9.05 | A, B, | 50 - 300 | 9.05 | 100 | 9.11 | 9.22 - 9.57 | O.D. | 8.00 | |
| | | | C, D, | 350 | 9.30 | 150 | 9.11 | 9.27 - 9.57 | STD. | 8.63 | |
| | | | E, F | | 9.42 | 200 | 9.11 | 9.39 - 9.74 | | | |
| 9" | | | | | | | | STD. | 9.63 | | |
| 10" | 10.75 | 11.10 | A, B, | 50 - 200 | 11.10 | 100 | 11.24 | 11.42 - 11.77 | O.D. | 10.00 | |
| | | | C, D, | 250 - 350 | 11.40 | 150 | 11.66 | 11.82 - 12.12 | STD. | 10.75 | |
| | | | E, F | | 11.60 | 200 | 11.66 | 11.77 - 12.12 | | | |
| 12" | 12.75 | 13.20 | A, B, | 50 - 200 | 13.20 | 100 | 13.44 | 13.69 - 14.04 | O.D. | 12.00 | |
| | | | C, D, | 250 - 350 | 13.50 | 150 | 13.92 | 14.08 - 14.38 | STD. | 12.75 | |
| | | | E, F | | 13.76 | 200 | 13.92 | 14.03 - 14.38 | | | |
| 14" | 14.00 | 15.30 | A, B, | 50 - 100 | 15.30 | 100 | 15.07 | 15.40 - 15.80 | STD. | 14.00 | |
| | | | C, D, | 150 - 300 | 15.65 | 150 | 16.22 | 16.38 - 16.73 | | | |
| | | | E, F | | 15.98 | 200 | 16.22 | 16.48 - 16.88 | | | |
| 16" | 16.00 | 17.40 | A, B, | 50 - 100 | 17.40 | 100 | 17.14 | 17.54 - 17.94 | STD. | 16.00 | |
| | | | C, D, | 150 - 300 | 17.80 | 150 | 18.46 | 18.62 - 18.97 | | | |
| | | | E, F | | 18.16 | 200 | 18.46 | 18.79 - 19.19 | | | |
| 18" | 18.00 | 19.50 | A, B | 50 - 100 | 19.50 | 100 | 19.90 | 20.44 | STD. | 18.00 | |
| | | | C, D | 150 - 250 | 19.92 | 150 | 20.94 | 21.20 | | | |
| | | | | | | 200 | 22.18 | | | | |
| 20" | 20.00 | 21.60 | A, B, | 50 - 100 | 21.60 | 100 | 22.12 | 22.50 | STD. | 20.00 | |
| | | | C, D | 150 - 250 | 22.06 | 150 | 23.28 | 23.54 | | | |
| | | | | | | 200 | 24.66 | | | | |
| 22" | | | | | | | | STD. | 22.00 | | |
| 24" | 24.00 | 25.80 | A, B, | 50 - 100 | 25.80 | 100 | 26.48 | 27.17 | STD. | 24.00 | |
| | | | C, D | 150 - 250 | 26.32 | 150 | 27.96 | 28.22 | | | |
| | | | | | | 200 | 29.62 | | | | |
| 30" | 30.00 | 32.00 | A | | 31.74 | | | | STD. | 30.00 | |
| | | | B | 50 - 350 | 32.00 | | | | | | |
| | | | C | | 32.40 | | | | | | |
| | | | D | | 32.74 | | | | | | |
| 36" | 36.00 | 38.30 | A | | 37.96 | | | | STD. | 36.00 | |
| | | | B | 50 - 350 | 38.30 | | | | | | |
| | | | C | | 38.70 | | | | | | |
| | | | D | | 39.16 | | | | | | |
| 42" | | 44.50 | A | | 44.20 | | | | STD. | 42.00 | |
| | | | B | 50 - 350 | 44.50 | | | | | | |
| | | | C | | 45.10 | | | | | | |
| | | | D | | 45.58 | | | | | | |
| 48" | | 50.80 | A | | 50.50 | | | | STD. | 48.00 | |
| | | | B | 50 - 350 | 50.80 | | | | | | |
| | | | C | | 51.40 | | | | | | |
| | | | D | | 51.98 | | | | | | |
| 54" | | | A | | 56.66 | | | | STD. | 54.00 | |
| | | | B | | 57.10 | | | | | | |
| | | | | 50 - 350 | 57.56 | | | | | | |
| | | | C | | 57.80 | | | | | | |
| 60" | | | D | | 58.40 | | | | STD. | 60.00 | |
| | | | | 50 - 350 | 61.61 | | | | | | |
| | | | A | | 62.80 | | | | | | |
| | | | B | | 63.40 | | | | | | |
| | | | C | | 64.20 | | | | | | |
| | | | D | | 64.82 | | | | | | |

Note: Due to variations in outside diameters and specifications, dimensions listed above are approximate. For this reason, determine the pipe O.D. before ordering.

INSTALLATION INSTRUCTIONS FOR FORD FABRICATED STEEL COUPLINGS

1. MEASURE PIPE DIAMETER CAREFULLY USING A RELIABLE OUTSIDE DIAMETER TAPE. (O.D. MAY ALSO BE DETERMINED BY USING A STANDARD TAPE TO MEASURE CIRCUMFERENCE AND DIVIDING BY 3.1416) MAKE SURE PIPE O.D. IS WITHIN RANGE LIMITS OF COUPLING AS LISTED IN CATALOG SECTION N.
2. PIPE ENDS SHOULD BE FREE OF ALL DIRT, LOOSE SCALE AND RUST ALONG AN AREA APPROXIMATELY 2" GREATER THAN THE LENGTH OF THE COUPLING. THE USE OF A WIRE BRUSH OR SCRAPING DEVICE IS RECOMMENDED. ANY WELDS REMAINING ON A PIPE END MUST BE GROUND TO A SMOOTH SURFACE.
3. BEGIN ASSEMBLY BY SLIDING AN END RING ON EACH PIPE END.
4. PLACE A GASKET ON EACH PIPE WITH THE BEVELED EDGE FACING THE PIPE END. A NON-PETROLEUM BASED LUBRICANT SUITABLE FOR POTABLE WATER APPLIED TO THE GASKET WILL ASSIST ASSEMBLY ONTO THE PIPE AND WILL ALLOW FOR PROPER SEATING OF THE GASKET INTO THE COUPLING. WHEN WORKING IN COLD CONDITIONS, WARM GASKET TO 65 DEGREES BEFORE INSTALLATION TO ENHANCE ELASTICITY.
5. SLIDE CENTER SLEEVE ON TO ONE PIPE END THEN CENTER THE SLEEVE OVER THE GAP BETWEEN THE TWO PIPE ENDS. REFER TO CHART FOR OPTIMUM GAP BETWEEN PIPE ENDS. **(IT IS EXTREMELY IMPORTANT THAT THE SPACE BETWEEN THE PIPE'S O.D. AND THE CENTER SLEEVE'S I.D. BE DISTRIBUTED AS EVENLY AS POSSIBLE DURING INSTALLATION BY BLOCKING AND SHIMMING PIPE AND COUPLING COMPONENTS.)**

| SLEEVE LENGTH | OPTIMUM GAP |
|---------------|-------------|
| 5" | .50" |
| 6" | .50" |
| 7" | 1.00" |
| 10" | 1.00" |

- 6 LUBRICATE BEVELED SURFACE OF CENTER SLEEVE, THE PIPE ENDS AND THE GASKETS BEFORE SLIDING ALL COMPONENTS TOGETHER TO ENSURE PROPER GASKET SEATING. CHECK GASKET AND CENTER SLEEVE TO ENSURE THE ABSENCE OF FOREIGN MATERIAL THAT WOULD INTERFERE WITH PROPER GASKET SEATING.
7. INSERT ALL BOLTS AND TIGHTEN FINGER TIGHT. EVENLY TIGHTEN BOLTS IN AN ALTERNATING PATTERN BEING CERTAIN THAT END RINGS REMAIN PARALLEL TO ONE ANOTHER AND PERPENDICULAR TO THE CENTER LINE OF THE PIPE. COMPLETE TIGHTENING BY USING A TORQUE WRENCH SET AT 40 - 50 FT. LBS. FOR 1/2" BOLTS AND 60 - 70 FT. LBS. FOR 5/8" BOLTS.
8. RECHECK THE TORQUE ON THE BOLTS BEFORE BACKFILLING THE TRENCH. IF A LEAK DEVELOPS DURING TESTING TIGHTEN BOLTS AS NECESSARY TO STOP LEAK MAKING SURE NOT TO OVER- STRESS ANY OF THE COUPLING COMPONENTS.

**PLEASE REFER TO AWWA C219 FOR DETAILED PERFORMANCE STANDARDS AND
INSTALLATION PRACTICES FOR FABRICATED STEEL COUPLING PRODUCTS.**

CAUTION

- FLEXIBLE COUPLINGS DO NOT RESTRAIN AXIAL MOVEMENT OF PIPE.
- FLEXIBLE COUPLINGS ARE DESIGNED TO FLOAT ON PIPE ENDS AND ARE NOT DESIGNED TO SUPPORT THE PIPE.

Section **N**

Ford Fabricated Steel Products

Warranty

All merchandise is warranted to be free from defects in material and factory workmanship for one year from date of shipment from our factory. We will provide, free of charge, new products in equal quantities for any that prove defective within one year from date of shipment from our factory. Manufacturer shall not be liable for any loss, damage, or injury, direct or consequential, arising out of the use of or the inability to use the product. Before using, user shall determine the suitability of the product for user's intended use and user assumes all risk and liability whatever in connection therewith. No claims for labor or consequential damage will be allowed. The foregoing may not be changed except by agreement signed by an officer of the manufacturer.

No other warranties are applicable or may be implied, including the implied warranty of merchantability and the implied warranty of fitness for particular purpose and any warranty relating to infringement or the like, all of which are disclaimed.

Please Note:

Consult The Ford Meter Box Company, Inc. website (www.fordmeterbox.com) for the most recent catalog information. The Ford Meter Box Company considers the information in this catalog to be correct at the time of publication. Items and option availability, including specifications, are subject to change without notice. Please verify that your product information is current.



The Ford Meter Box Co., Inc. 775 Manchester Avenue, P.O. Box 443, Wabash, Indiana, USA 46992-0443
Telephone: 260/563-3171 FAX: 1-800-826-3487 Overseas FAX: 260/563-0167 www.fordmeterbox.com